

VOLVO PENTA 1500rpm/1800 rpm	Document No	Issue Index
	23466372	03

Base on water temp 38°C/100°F

General

In-line four stroke diesel engine with direct injection. Rotation direction, anti-clockwise viewed towards flywheel. Turbocharged

Number of cylinders		6	
Displacement, total	litre in ³	12.78 779.7	
Firing order		1-5-3-6-2-4	
Bore	mm in	131 5.16	
Stroke	mm in	158 6.22	
Compression ratio		18.5	
Dry weight	Engine only, excluding cooling system	kg lb	1520 3351
	Genset, see dimension drawing	kg lb	

		rpm	1500				
Performance		load	25%	50%	75%	100%	110%
Power setting 300 kW		kW	75	150	225	300	330
		hp	102	204	306	408	449
Torque at:	Power setting 300 kW	Nm	477	955	1432	1910	2101
		lbft	352	704	1056	1409	1549
Mean piston speed		m/s	7.9				
		ft/sec	26.0				
Effective mean pressure at:	Power setting 300 kW	MPa	0.5	0.9	1.4	1.9	2.1
		psi	68	136	204	272	300
Max combustion pressure at:	Power setting 300 kW	MPa	8.2	10.5	13.5	16.6	18
		psi	1189	1523	1958	2408	2611
Total mass moment of inertia, J (mR ²) Engine only		kgm ²	3.43				
		lbft ²	81.4				
Friction Power		kW	32	32	32	32	32
		hp	43	43	43	43	43

		rpm	1800				
Performance		load	25%	50%	75%	100%	110%
Power setting 360 kW		kW	90	180	270	360	396
		hp	122	245	367	490	539
Torque at:	Power setting 360 kW	Nm	477	955	1432	1910	2101
		lbft	352	704	1056	1409	1549
Mean piston speed		m/s	9.5				
		ft/sec	31.2				
Effective mean pressure at:	Power setting 360 kW	MPa	0.5	0.9	1.4	1.9	2.1
		psi	68	136	204	272	300
Max combustion pressure at:	Power setting 360 kW	MPa	8.3	10.6	13.9	17.7	19.3
		psi	1204	1537	2016	2567	2799
Total mass moment of inertia, J (mR ²) Engine only		kgm ²	3.43				
		lbft ²	81.4				
Friction Power		kW	45	45	45	45	45
		hp	61.2	61.2	61.2	61.2	61.2

Engine noise emission

Test Standards: ISO 3744-1981 (E) sound power (without intake and exhaust noise)

Tolerans ± 0.75 dB(A)

		rpm	1500				
		load	25%	50%	75%	100%	110%
Measured sound power Lw	No load	dB(A)	107.5	107.5	107.5	107.5	107.5
	Power setting 300 kW	dB(A)	109.5	109.9	110.4	111	111
		rpm	1800				
Measured sound power Lw	No load	dB(A)	109.1	109.1	109.1	109.1	109.1
	Power setting 360 kW	dB(A)	111.4	112.3	112.7	113.4	113.2

VOLVO PENTA 1500rpm/1800 rpm	Document No	Issue Index
	23466372	03

Vibrations (vibration velocity)

Power:	kW	300
Speed:	rpm	1500
Ambient temperature	°C	29-36
Type of Fuel		SD10

Measuring Point No	Rms overall values (2 Hz to 1000 Hz) (calculated)									Remarks
	Direction of Measurement									Prime
	Axial (x) [mm]	Axial (x) [mm/s]	Axial (x) [m/s ²]	Transverse (y) [mm]	Transverse (y) [mm/s]	Transverse (y) [m/s ²]	Vertical (z) [mm]	Vertical (z) [mm/s]	Vertical (z) [m/s ²]	
1	0.183	8.5	9.9	0.395	11.1	11.8	0.15	10.4	9.2	Engine
2	0.212	8.2	7.9	0.529	11.5	8.7	0.192	8.8	8.9	
3	0.228	9.5	10.2	0.396	15.1	18.1	0.141	11.8	12.1	
4	0.171	9.2	15.6	0.193	11.1	16.5	0.16	9.4	14	
5	0.093	16.7	11.2	0.104	8.1	8.3	0.098	14.6	12.6	Generator
6	0.054	15.8	11.6	0.085	16.7	8.5	0.049	14.7	10.7	
7	0.085	8.5	4.5	0.079	16	8.5	0.106	18.1	10.7	
8	0.093	8.2	4.5	0.093	14.8	8.4	0.096	17.1	10.4	

Power:	kW	360
Speed:	rpm	1800
Ambient temperature	°C	29-36
Type of Fuel		SD10

Measuring Point No	Rms overall values (2 Hz to 1000 Hz) (calculated)									Remarks
	Direction of Measurement									Prime
	Axial (x) [mm]	Axial (x) [mm/s]	Axial (x) [m/s ²]	Transverse (y) [mm]	Transverse (y) [mm/s]	Transverse (y) [m/s ²]	Vertical (z) [mm]	Vertical (z) [mm/s]	Vertical (z) [m/s ²]	
1	0.201	10.6	11.2	0.448	13.4	12.9	0.194	12.3	13.8	Engine
2	0.591	16.9	10.4	0.601	17.7	11.1	0.272	19.5	14.8	
3	0.227	11.1	13.5	0.217	18.3	25.2	0.118	14	17	
4	0.338	13.3	20.6	0.369	21.7	23.5	0.249	21.5	18.7	
5	0.096	18.4	13.1	0.102	10.4	9.9	0.096	19.2	14.5	Generator
6	0.068	18	14.9	0.092	16.4	11.6	0.054	15	10.5	
7	0.092	11.3	7.4	0.077	17.1	12.4	0.106	25	15.6	
8	0.095	11.2	7.4	0.085	16.7	11.9	0.098	21.9	14.4	

Declared vibration levels according to ISO 8528-9

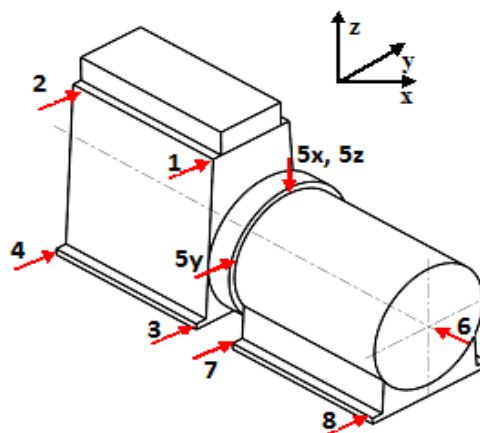

VOLVO PENTA 1500rpm/1800 rpm	Document No	Issue Index
	23466372	03

Test conditions for load acceptance data

Warm engine.	Generator	Modell	Type of AVR
	Stamford	HCI534D1	MX341

Load acceptance performance can vary due to actual alternator inertia, voltage regulator, type of load and local ambient conditions.

Single step load performance at 1500 rpm

Load (%)	Speed diff (%)		Recovery time (s)		Remaining load (%)	Speed diff (%)		Recovery time (s)	
	Nominal	110% power	Nominal	110% power		Nominal	110% power	Nominal	110% power
0-20	2.4	2.7	1.5	1.4	20-100	14.9	18.2	3.7	5.2
0-40	4.1	4.5	1.5	1.5	40-100	9.1	11.6	2.7	4.0
0-60	6.5	7.7	2.0	2.3	60-100	4.1	6.0	1.6	3.2
0-80	12.4	15.0	3.2	3.6	80-100	2.1	2.4	1.0	1.3
0-100	23.4	32.2	5.2	8.8					
0-72.2	9.5		2.3		72.2-100	3.1		0.9	
0-65.4		9.8		2.4	65.4-100		5.3		2.3
0-63	7.2		2.2		63-100	3.7		1.3	
0-57		7.2		2.2	57-100		6.6		3.1
100-0						-5.3	-4.3	1.1	1.1

Single step load performance at 1800 rpm

Load (%)	Speed diff %		Recovery time (s)		Remaining load (%)	Speed diff (%)		Recovery time (s)	
	Nominal	110% power	Nominal	110% power		Nominal	110% power	Nominal	110% power
0-20	1.8	1.9	0.9	0.8	20-100	8.8	11.6	2.9	3.9
0-40	3.1	3.1	1.2	1.0	40-100	6.9	9.3	2.5	3.5
0-60	4.3	4.9	1.4	1.6	60-100	3.5	4.6	1.5	2.3
0-80	7.5	10.4	2.6	2.9	80-100	1.4	1.5	0.7	1.0
0-100	14.1	17.1	3.7	8.6					
0-87.8	10.2		2.7		87.8-100	0.8		0.5	
0-80.1		10.6		2.7	80.1-100		1.5		0.8
0-76.6	6.6		2.4		76.6-100	1.6		0.7	
0-69.8		6.7		2.4	69.8-100		2.5		1.6
100-0						-3.6	-2.9	1.3	1.2

VOLVO PENTA 1500rpm/1800 rpm	Document No	Issue Index
	23466372	03

Cold start performance

		rpm	1500	1800
Time from start to stay within 0.5% of no load speed at ambient temperature:	20°C	s	4.8	4.6
	5 °C	s	5.7	5.2

Lubrication system		rpm	load	25%	50%	1500 75%	100%	110%
Lubricating oil consumption	Power setting 300 kW	liter/h		0.005	0.010	0.015	0.020	0.023
		US gal/h		0.001	0.003	0.004	0.005	0.006
		rpm		1800				
	Power setting 360 kW	liter/h		0.006	0.012	0.018	0.025	0.027
		US gal/h		0.002	0.003	0.005	0.007	0.007
Oil system capacity including filters		liter		49				
		US gal		12.9				
Oil sump capacity:	max	liter		44				
		US gal		11.6				
	min	liter		35				
		US gal		9.2				
Oil change intervals/ specifications: (Fuel quality dependant)	VDS-3	h		600				
	VDS-2	h		400				
		h						
		h						
Engine angularity limits, static (ref. classification rules, roll and pitch simultaneously)	front up	°		36				
	front down	°		36				
	side tilt	°		36				

Lubrication system

		rpm	1500	1800
Oil pressure at rated speed		kPa	360	450
		psi	52.2	65.3
Lubrication oil temperature in oil sump:	max	°C	110	
		°F	230	
Oil filter micron size		μ	40	

* See also general section in the sales guide

VOLVO PENTA 1500rpm/1800 rpm	Document No	Issue Index
	23466372	03

Fuel system		rpm load	1500				
			25%	50%	75%	100%	110%
Specific fuel consumption with:	Power setting 300 kW	g/kWh lb/hph	231 0.375	202 0.328	194 0.314	190 0.309	190 0.308
		rpm 1800					
	Power setting 360 kW	g/kWh lb/hph	248 0.402	213 0.344	200 0.324	200 0.324	197 0.319
Fuel to conform to		ASTM-D975-No. 1 and 2-D, JIS KK 2204, EN 590 MDO-DMX and MDO-DMA (ISO8217)					
		rpm 1500					
System return flow	Power setting 300 kW	liter/h US gal/h	53 14.0	52 13.7	52 13.7	52 13.7	51 13.5
		rpm 1800					
	Power setting 360 kW	liter/h US gal/h	56 14.8	56 14.8	55 14.5	55 14.5	55 14.5
		rpm 1500					
System supply flow	Power setting 300 kW	liter/h US gal/h	74 19.6	89 23.5	105 27.7	121 32.0	128 33.8
		rpm 1800					
	Power setting 360 kW	liter/h US gal/h	82 21.7	102 26.9	120 31.7	141 37.3	151 39.9
		rpm 1500					
Normal fuel pressure (after filter)	Power setting 300 kW	kPa psi	582 84.4	576 83.5	570 82.7	564 81.8	561 81.4
		rpm 1800					
	Power setting 360 kW	kPa psi	608 88.2	600 87.0	593 86.0	585 84.8	583 84.6

Fuel system

Fuel supply line max restriction	kPa psi	30.0 4.4
Fuel supply max pressure head (day tank, from CL)	m feet	2.0 6.6
Fuel supply line max suction head (from CL)	kPa psi	4.0 0.6
Fuel return line max restriction	kPa psi	20.0 2.9
Maximum allowable inlet fuel temp	°C °F	50 122
Fuel filter micron size	μ	2

VOLVO PENTA 1500rpm/1800 rpm	Document No	Issue Index
	23466372	03

Intake system		rpm load	25%	50%	1500 75%	100%	110%
Air consumption at: (+25°C and 100kPa)	Power setting 300 kW	m ³ /min	10.5	13.7	17.8	21.7	23.0
		cfm	372	482	629	766	813
		rpm	1800				
	Power setting 360 kW	m ³ /min	14.3	16.3	21.0	24.7	26.8
		cfm	503	575	741	871	947
Max allowable air intake restriction including piping		kPa	6				
		psi	0.9				
Air filter type		Paper cartridge					
Air filter cleaning efficiency		%	98.5				

Exhaust system		rpm load	25%	50%	1500 75%	100%	110%
Heat rejection to exhaust at:	Power setting 300 kW	kW	57	99	137	172	190
		BTU/min	3242	5636	7791	9776	10805
		rpm	1800				
	Power setting 360 kW	kW	77	129	173	223	245
		BTU/min	4373	7319	9833	12670	13933

Exhaust system		rpm load	25%	50%	1500 75%	100%	110%
Exhaust gas temperature after turbine at:	Power setting 300 kW	°C	285	356	377	391	398
		°F	545	673	711	736	748
		rpm	1800				
	Power setting 360 kW	°C	260	301	337	399	423
		°F	500	574	639	750	793
Exhaust back pressure after turbocharger during test		kPa	12				
		psi	1.7				
Permitted exhaust back pressure after turbocharger		kPa	17				
		psi	2.5				

Exhaust system		rpm load	25%	50%	1500 75%	100%	110%
Exhaust gas flow at: (temp and pressure after turbine at the corresponding power setting)	Power setting 300 kW	m ³ /min	20.2	29.3	38.9	47.5	50.5
		cfm	712	1035	1373	1676	1782
		rpm	1800				
	Power setting 360 kW	m ³ /min	26.6	36.6	46.5	56.8	60.9
		cfm	940	1293	1643	2004	2149

VOLVO PENTA 1500rpm/1800 rpm	Document No	Issue Index
	23466372	03

Cooling system, HT circuit, heat rejection		rpm load	1500				
			25%	50%	75%	100%	110%
Heat rejection radiation from engine to surrounding at:	Power setting 300 kW	kW	4	4	5	5	5
		BTU/min	227	227	284	284	284
			1800				
	Power setting 360 kW	kW	4	4	5	5	5
BTU/min		227	227	284	284	284	

Cooling system, HT circuit, heat rejection		rpm	1500				
			62	100	125	155	172
Heat rejection to coolant at: (HT)	Power setting 300 kW	kW	62	100	125	155	172
		BTU/min	3526	5687	7109	8815	9781
			1800				
	Power setting 360 kW	kW	80	124	153	190	205
BTU/min		4550	7052	8701	10805	11658	

Cooling system, HT circuit, other data				
Coolant volume in engine with std. expansion tank	liter	38		Note! Expansion tank size to be calculated.
	US gal	10.04		
Max. additional coolant in HT system with std. expansion tank	liter			Recomended. 15% of total coolant volume
	US gal			
Coolant pump	drive/ratio	1/1.5		
		rpm	1500	1800
Coolant flow with fully open thermostat		l/s	1.53	3.6
		US gal/s	0.40	0.95
Nominal coolant pressure with standard system		kPa	180.0	227.0
		psi	26.1	32.9
Maximum external coolant system restriction, including piping		kPa	85	85
		psi	12.3	12.3
Thermostat	start to open	°C	82	
		°F	180	
	fully open	°C	92	
		°F	198	
Design point for box cooler, engine outlet temperature		°C	90	89
		°F	194	192
Coolant flow at design point		l/s	1.30	2.50
		US gal/s	0.34	0.66
Maximum static pressure head (expansion tank height + pressure cap setting)		kPa	85	
		psi	12.3	
Standard pressure cap setting		kPa	75	
		psi	10.9	
Maximum temperature entering engine		°C	60	70
		°F	140	158
Coolant (40% coolant / 60% water)	See Operators Manual			

VOLVO PENTA 1500rpm/1800 rpm	Document No	Issue Index
	23466372	03

Cooling system, LT circuit, heat rejection		rpm load	25%	50%	1500	100%	110%
			75%				
Heat rejection to coolant at: (LT)	Power setting 300 kW	kW	10	16	32	49	59
		BTU/min	569	910	1820	2787	3355
		rpm	1800				
	Power setting 360 kW	kW	13	19	41	70	82
		BTU/min	739	1081	2332	3981	4663

Cooling system, LT, other data

Coolant volume in engine charge air cooler circuit	liter US gal	7 1.85	Note! Expansion tank size to be calculated. Recommended. 15% of total coolant volume
Max. additional coolant in LT system with std. expansion tank	liter US gal		
Maximum static pressure head (expansion tank height + pressure cap setting)	kPa psi	85 12.3	
Standard pressure cap setting	kPa psi	75 10.9	
LT circuit pump	drive/ratio	1/1.5	
	rpm	1500	1800
Nominal LT water design flow	l/s	1.36	1.63
	US gal/s	0.36	0.43
Nominal LT water pump pressure head at design flow	kPa	86	88
	psi	12.5	12.8
Maximum LT waterpump suction head	kPa	-14	-19
	psi	-2.0	-2.8
Maximum additional pressure drop LT water circuit	kPa	105	107
	psi	15.2	15.5
Maximum allowed LT water circuit pressure before Heat Exchanger (External pump system)	kPa	72	65
	psi	10.4	9.4
Maximum temperature entering charge air cooler	°C	38	
	°F	100	
Coolant (40% coolant / 60%water)	See Operators Manual		

VOLVO PENTA 1500rpm/1800 rpm	Document No	Issue Index
	23466372	03

Charge air cooler system		rpm load	25%	50%	1500 75%	100%	110%	
Cooling power	Power setting 300 kW	kW	10	16	32	49	59	
		BTU/min	569	910	1820	2787	3355	
			rpm	1800				
	Power setting 360 kW	kW	13	19	41	70	82	
BTU/min		739	1081	2332	3981	4663		
		rpm	1500					
Charge air mass flow	Power setting 300 kW	kg/s	0.22	0.27	0.36	0.42	0.45	
				rpm	1800			
	Power setting 360 kW	kg/s	0.29	0.32	0.43	0.53	0.56	
				rpm	1500			
Charge air inlet temp. Charge air temp after turbo compressor)	Power setting 300 kW	°C	66	88	126	153	170	
		°F	151	190	259	307	338	
			rpm	1800				
	Power setting 360 kW	°C	79	94	133	171	185	
°F		174	201	271	340	365		

Charge air cooler system		rpm load	25%	50%	1500 75%	100%	110%	
Charge air outlet temp. (Charge air temp after charge air cooler)	Power setting 300 kW	°C	30	35	36	37	43	
		°F	86	95	97	99	109	
			rpm	1800				
	Power setting 360 kW	°C	33	35	37	40	41	
°F		91	95	99	104	106		
Maximum pressure drop over charge air cooler, incl. piping		kPa	1.2					
		psi	0.17					
		rpm	1500					
Charge air pressure	Power setting 300 kW	kPa	238					
		psi	34.52					
			rpm	1800				
	Power setting 360 kW	kPa	239					
psi		34.66						

VOLVO PENTA 1500rpm/1800 rpm	Document No	Issue Index
	23466372	03

Engine management system

Functionality	Alternatives	Default setting
Governor mode	Isochronus/Droop	Droop
Governor droop	0/0, 1-5%	4%
Governor response	Adjustable PID (service tool)	0/0/0
Idle speed	600-1200	900
Fine speed adjustment	±90	0
Stop function	Normaly Closed/Normaly Opened	Depends on order

Electrical system**rpm 1500 and 1800**

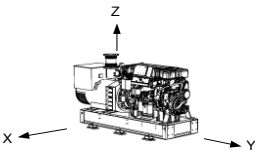
Voltage and type		24V / insulated from earth	
Alternator:	make/output	Amp	Bosch/110A
	tacho output	Hz/alt. Rev	6
	drive ratio		3.7:1
Starter motor	make	Melco	
	type	105P70	
	kW	7.0	
Starter motor solenoid,	pull current	Amp	280
	hold current	Amp	-
Number of teeth on:	flywheel		153
	starter motor		12
Inrush current at +20°C \ 5°C		Amp	1020 \ 1560
Cranking current at +20°C \ 5°C		Amp	400 \ 530
Crank engine speed at 20°C \ 5°C		rpm	150 \ 130
Starter motor battery capacity:	max	Ah	2x220
	min at +5°C	Ah	2x180
Max. g-force 	x	m/s ²	2
	y	m/s ²	2
	z	m/s ²	6

VOLVO PENTA

KC 300/360

1500rpm/1800 rpm

Document No

23466372

Issue Index

03

Sensors : Control and Monitoring System							Engine protection action
Sensors	Signal	Range	Unit	Warning Initial Delay / Warning Delay	Warning Level	Derating Level	
AUS/DEF concentration	Ultrasonic 1 Hz	0 - 62.5	%	N/A	<28	N/A	Warning only
AUS/DEF Tank Empty	Ultrasonic 1 Hz	0-100	%	30 sec	0	N/A	Warning only
AUS/DEF Tank Low level	Ultrasonic 1 Hz	0-100	%	30 sec	15	N/A	Warning only
AUS/DEF tank temp High alarm	Resistive	-40 - 125 ±1.5°C	°C	1 sec	70	N/A	Warning only
Coolant level switch	Digital	ON/OFF		30 sec from start / 11 sec	Low	N/A	Warning only
Coolant temperature	50-0 kΩ	-40 - 140 ±1.5°C	°C	30 sec from start / 2 sec	98	N/A	Warning only
Engine speed cam	Frequency		rpm	Instant	Lost signal	N/A	Warning only
Engine speed crank	Frequency		rpm	Instant	Lost signal	N/A	Warning only
Exhaust gas temperature after turbine	PT200	-40 - 750 ± 2.5%	°C	30 sec from start / 2 sec	532	N/A	Warning only
					N/A	N/A	Warning only
Oil level sensor	Digital	± 1.9 mm		30 sec from start / 5 sec	Low level	N/A	Warning only
Oil temperature	50-0 kΩ	-40 - 140 ± 1.5°C	°C	30 sec from start/1.5 sec	125	N/A	Warning only
Exhaust temperature before muffler	PT200	-40 - 750 ± 2.5%	°C	30 sec from start / 2 sec	532	N/A	Warning only
Water In fuel switch	Digital	ON/OFF		Instant	Water in fuel	N/A	Warning only
Wet Exhaust temp	PT200	0 - 850	°C	30 sec from start / 5 sec	192	N/A	Warning only

VOLVO PENTA

KC 300/360

1500rpm/1800 rpm

Document No

23466372

Issue Index

03

Sensors (rpm dependent)	Signal	Range	Unit	Initial Delay / Delay	Warning Level / Derating Level / Shutdown Level rpm Map				Comment
Charge air pressure	0,5-4,5 V	50-600 ±4.2 kPa	kPa				1500 rpm	1800 rpm	
Warning Level			kPa	30 sec from start / 2.2 sec			290	270	
Derating Level			kPa	NA			NA	NA	
Charge air temperature	50-0 kΩ	-40 - 130 ±4%	°C				1500 rpm	1800 rpm	
Warning Level			°C	60 sec from start / 15 sec			80	76	
Derating Level			°C	NA			NA	NA	
Coolant pressure	0,5-4,5 V	0-300±3%	kPa				1500 rpm	1800 rpm	
Warning Level			kPa	30 sec from start / 1.5sec			50	76	
Derating Level			kPa	NA			NA	NA	
Fuel pressure	0,5-4,5 V	0-700±2.5%	kPa				1500 rpm	1800 rpm	
Warning Level			kPa	60 sec from start / 5 sec			205	280	
Derating Level			kPa	NA			NA	NA	
Oil pressure	0,5-4,5 V	0-700±2.5%	kPa				1500 rpm	1800 rpm	
Warning Level			kPa	30 sec from start / 3 sec			260	260	
Derating Level			kPa	NA			NA	NA	
Seawater pressure	0,5-4,5 V	0-300±3%	kPa				1500 rpm	1800 rpm	Only HE and KC
Warning Level			kPa	30 sec from start / 5 sec			30	45	
Derating Level			kPa	NA			NA	NA	

Warning = Yellow Lamp active

Derating = Red Lamp active

VOLVO PENTA

KC 300/360
1500rpm/1800 rpm

Document No	Issue Index
23466372	03

For SDM only

Sensors Control and Monitoring System											
Sensors	Signal	Range	Unit	Warning Initial Delay /	Shutdown level			Engine protection action			
Coolant temperature	Digital	ON/OFF ON= Shutdown	°C	12sec from start/1 sec	105			Shutdown			
Eng. overspeed SDM 1500+15%	Frequency	153 puls./rev	rpm / Hz	Instant	1725 rpm / 4399 Hz			Shutdown			
Eng. overspeed SDM 1800+15%	Frequency	153 puls./rev	rpm / Hz	Instant	2070 rpm / 5278 Hz			Shutdown			
Sensors (rpm dependent)	Signal	Range	Unit	Initial Delay / Delay	Warning Level / Derating Level / Shutdown Level					Engine protection action	
					0 rpm	600 rpm	1000 rpm	1500 rpm	1800 rpm		
Oil pressure <input type="checkbox"/>	Digital <input type="checkbox"/>	ON/OFF	kPa	12 sec from start / 1 sec	NA	120 ±20	120 ±20	120 ±20	120 ±20	Shutdown	

VOLVO PENTA KC 300/360 1500rpm/1800 rpm	Document No	Issue Index
	23466372	03

Technical data - Exhaust AfterTreatment System data (EATS)

Weight data:

SCR system weight: (incl SCR unit, AUS injector pipe, AUS sensor and bracket)			kg	115.7
			lb	255.1
Total SCR system weight for IPS: (incl SCR unit, AUS injector pipe, AUS sensor and bracket, exhaust piping)			kg	115.7
			lb	255.1
AUS pump			kg	3.1
			lb	6.8
AUS cabinet 20l weight: (incl tank, pump,UQS, ACM)			kg	36.4
			lb	80.2
AUS tank 160l weight:			kg	45
			lb	99.2
UQS - Lenght/Weight	mm	439	kg	1.2
	in	17.3	lb	2.6
UQS - Lenght/Weight	mm	597	kg	1.2
	in	23.5	lb	2.6
UQS - Lenght/Weight	mm	715	kg	1.3
	in	28.1	lb	2.9

Dimension data:

SCR Surface area		m2/ft2	2.2 / 23.7
SCR Flange:	Standard type		
	Diameter:	in/mm	6 in / 152 mm
	Number of Inlet / Outlet:	1 inlet / 2 outlet	

Flow data:

Max AUS flow to injector	l/h	7.9
	US gal/h	2.1
Max collant flow to AUS injector	l/h	6.7
	US gal/h	1.8

Exhaust system	Rating	rpm	600	800	1000	1200	1300	1400	1500	1600	1800	1900
Max allowable temperature drop between turbine and SCR muffler inlet.		°C							10		10	
		°F							50		50	
SCR muffler pressure drop at prop. load x ³		kPa							3		5	
		psi							0.4		0.7	
SCR muffler pressure drop at Full load		kPa							6		7	
		psi							0.9		1.0	

VOLVO PENTA KC 300/360 1500rpm/1800 rpm	Document No	Issue Index
	23466372	03

AUS system	Rating	rpm	600	800	1000	1200	1300	1400	1500	1600	1800	1900
Specific AUS consumption		g/kWh							14.40		12.00	
		lb/hph							0.02		0.02	
AUS consumption at Full load		l/h							4.54		5.57	
		US gal/h							1.20		1.47	

AUS concentration 32.5%

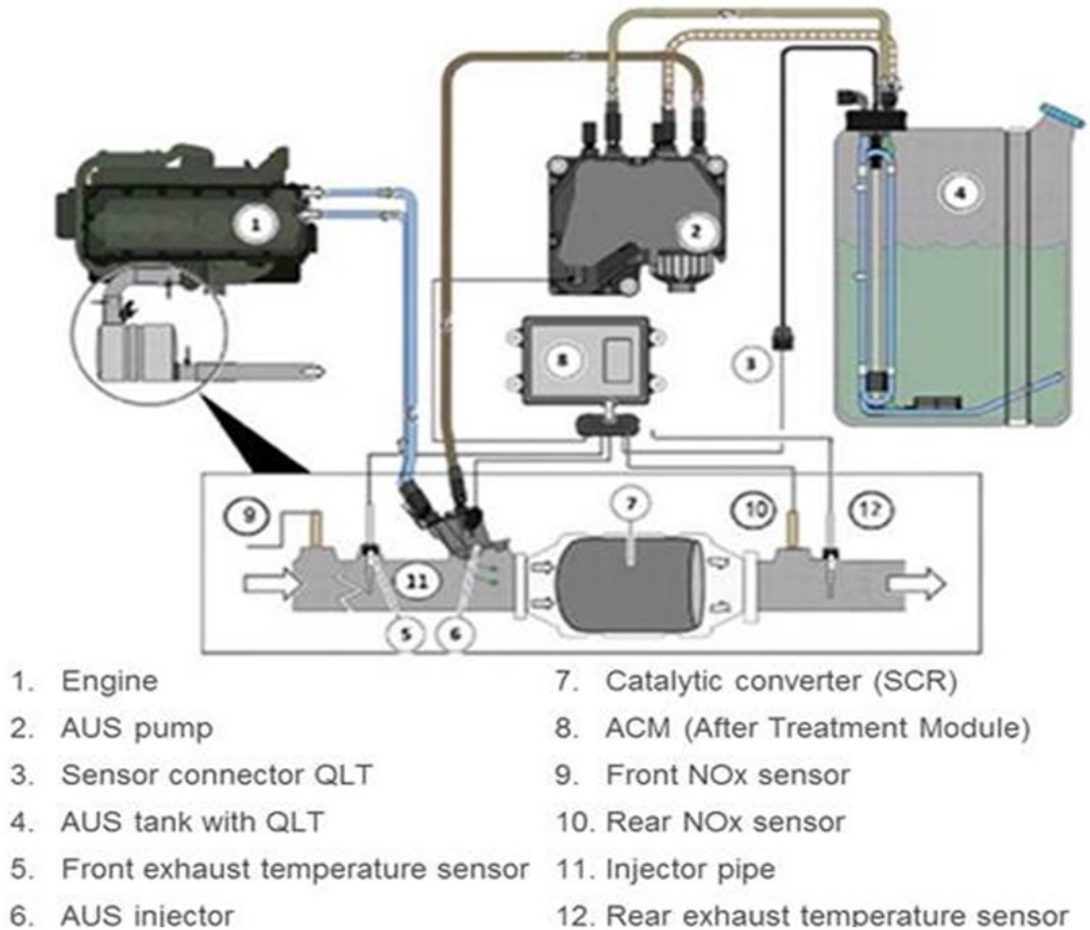

Abbreviations:

ACM	Aftertreatment Control Module
AUS	Aqueous Urea Solution
EATS	Exhaust Aftertreatment System
SCR	Selective Catalytic Reduction
UDS	Urea Dosing System
UQS	Urea Quality Sensor

