

<b>VOLVO PENTA</b> <b>1500rpm/1800 rpm</b>	Document No	Issue Index
	<b>23466373</b>	<b>03</b>

Base on water temp 38°C/100°F

**General**

In-line four stroke diesel engine with direct injection. Rotation direction, anti-clockwise viewed towards flywheel. Turbocharged

Number of cylinders		6	
Displacement, total	litre in <sup>3</sup>	12.78 779.7	
Firing order		1-5-3-6-2-4	
Bore	mm in	131 5.16	
Stroke	mm in	158 6.22	
Compression ratio		18.5	
Dry weight	Engine only, excluding cooling system	kg lb	1520 3351
	Genset, see dimension drawing	kg lb	

		rpm	1500				
<b>Performance</b>		load	25%	50%	75%	100%	110%
Power setting 360 kW		kW hp	90 122	180 245	270 367	360 490	396 539
Torque at:	Power setting 360 kW	Nm lbft	573 423	1146 845	1719 1268	2292 1690	2521 1859
Mean piston speed		m/s ft/sec	7.9 26.0				
Effective mean pressure at:	Power setting 360 kW	MPa psi	0.6 82	1.1 163	1.7 245	2.3 327	2.5 360
Max combustion pressure at:	Power setting 360 kW	MPa psi	8.5 1233	11.2 1624	15.4 2234	18.9 2741	20.1 2915
Total mass moment of inertia, J (mR <sup>2</sup> ) Engine only		kgm <sup>2</sup> lbft <sup>2</sup>	3.43 81.4				
Friction Power		kW hp	32 43	32 43	32 43	32 43	32 43

		rpm	1800				
<b>Performance</b>		load	25%	50%	75%	100%	110%
Power setting 400 kW		kW hp	100 136	200 272	300 408	400 544	440 598
Torque at:	Power setting 400 kW	Nm lbft	531 391	1061 783	1592 1174	2122 1565	2334 1722
Mean piston speed		m/s ft/sec	9.5 31.2				
Effective mean pressure at:	Power setting 400 kW	MPa psi	0.5 76	1.0 151	1.6 227	2.1 303	2.3 333
Max combustion pressure at:	Power setting 400 kW	MPa psi	8.7 1262	12.2 1769	15.5 2248	20 2901	20.8 3017
Total mass moment of inertia, J (mR <sup>2</sup> ) Engine only		kgm <sup>2</sup> lbft <sup>2</sup>	3.43 81.4				
Friction Power		kW hp	45 61.2	45 61.2	45 61.2	45 61.2	45 61.2

<b>VOLVO PENTA</b> <b>1500rpm/1800 rpm</b>	Document No	Issue Index
	<b>23466373</b>	<b>03</b>

**Engine noise emission**

Test Standards: ISO 3744-1981 (E) sound power (without intake and exhaust noise)

Tolerans ± 0.75 dB(A)

		rpm	1500				
			load	25%	50%	75%	100%
Measured sound power Lw	No load	dB(A)	107.5	107.5	107.5	107.5	107.5
	Power setting 360 kW	dB(A)	109.1	110.2	111	111	111.3
		rpm	1800				
Measured sound power Lw	No load	dB(A)	109.1	109.1	109.1	109.1	109.1
	Power setting 400 kW	dB(A)	111.4	112.6	112.7	113.3	113.1

**Vibrations (vibration velocity)**

Power:	kW	360
Speed:	rpm	1500
Ambient temperature	°C	29-36
Type of Fuel		SD10

Measuring Point No	Rms overall values (2 Hz to 1000 Hz) (calculated)									Remarks
	Direction of Measurement									
	Axial (x) [mm]	Axial (x) [mm/s]	Axial (x) [m/s^2]	Transverse (y) [mm]	Transverse (y) [mm/s]	Transverse (y) [m/s^2]	Vertical (z) [mm]	Vertical (z) [mm/s]	Vertical (z) [m/s^2]	
1	0.129	9.5	10.2	0.238	10.5	9.3	0.137	12.9	11.8	Engine
2	0.334	11.4	8.2	0.348	13.3	8.9	0.194	11.2	10	
3	0.207	12.3	11.3	0.332	13.8	17.3	0.141	14.5	13.3	
4	0.143	12.3	16.7	0.182	12.6	15.9	0.143	11.1	13.2	
5	0.097	19.9	12.9	0.106	8.9	8.2	0.095	17.8	14.6	Generator
6	0.058	18.3	13.2	0.101	19.6	10.1	0.053	16.6	12	
7	0.079	9.6	5	0.083	18.9	9.8	0.107	18.9	12.9	
8	0.089	9.4	5.1	0.089	17.3	9.5	0.097	21.5	12.5	

Power:	kW	400
Speed:	rpm	1800
Ambient temperature	°C	29-36
Type of Fuel		SD10

Measuring Point No	Rms overall values (2 Hz to 1000 Hz) (calculated)									Remarks
	Direction of Measurement									
	Axial (x) [mm]	Axial (x) [mm/s]	Axial (x) [m/s^2]	Transverse (y) [mm]	Transverse (y) [mm/s]	Transverse (y) [m/s^2]	Vertical (z) [mm]	Vertical (z) [mm/s]	Vertical (z) [m/s^2]	
1	0.166	11.8	11.4	0.344	12.7	12.4	0.162	14.2	15.8	Engine
2	0.577	17.7	10.9	0.764	22.5	12.4	0.293	21.9	16	
3	0.185	12.3	14.6	0.254	21.6	26.7	0.129	16.2	18.2	
4	0.293	13.4	20.8	0.307	24.9	24.2	0.212	24.5	21	
5	0.098	20.3	14.5	0.127	12.2	11.6	0.104	21.1	16.4	Generator
6	0.062	19.9	16.5	0.105	18.9	13.2	0.053	16.1	11.7	
7	0.087	13.6	8.8	0.08	19.3	13.8	0.105	29.5	18.2	
8	0.095	13.7	8.9	0.092	19	13.4	0.104	25.5	16.8	

Declared vibration levels according to ISO 8528-9

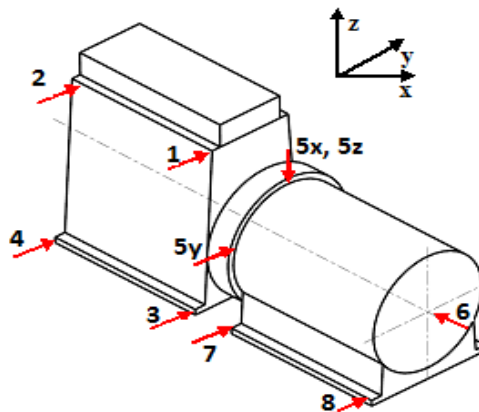

<b>VOLVO PENTA</b> 1500rpm/1800 rpm	Document No	Issue Index
	<b>23466373</b>	<b>03</b>

**Test conditions for load acceptance data**

Warm engine.	<b>Generator</b>	<b>Modell</b>	<b>Type of AVR</b>
	Stamford	HCI534D1	MX341

Load acceptance performance can vary due to actual alternator inertia, voltage regulator, type of load and local ambient conditions.

**Single step load performance at 1500 rpm**

Load (%)	Speed diff (%)		Recovery time (s)		Remaining load (%)	Speed diff (%)		Recovery time (s)	
	Nominal	110% power	Nominal	110% power		Nominal	110% power	Nominal	110% power
0-20	2.8	3.1	1.4	1.3	20-100	26.2	35.5	6.1	7.9
0-40	5.0	5.4	1.5	1.6	40-100	14.1	18.2	3.6	4.4
0-60	9.5	11.9	2.6	3.0	60-100	6.5	6.2	2.2	2.3
0-80	19.4	28.0	4.3	6.4	80-100	2.5	2.5	1.0	1.1
0-100	51.4	62.6	8.1	9.5					
0-60.4	9.8		2.4		60.4-100	6.2		1.8	
0-54.9		9.7		2.4	54.9-100		10.0		2.6
0-52.6	7.4		2.2		52.6-100	9.7		2.8	
0-47.9		7.4		2.2	47.9-100		12.8		3.4
100-0						-4.7	-4.0	1.2	1.3

**Single step load performance at 1800 rpm**

Load (%)	Speed diff %		Recovery time (s)		Remaining load (%)	Speed diff (%)		Recovery time (s)	
	Nominal	110% power	Nominal	110% power		Nominal	110% power	Nominal	110% power
0-20	1.9	2.0	0.8	0.9	20-100	10.9	15.2	3.2	4.1
0-40	3.2	3.4	1.1	1.1	40-100	9.1	12.3	3.1	3.6
0-60	5.0	6.3	1.6	2.2	60-100	4.2	6.5	1.7	2.6
0-80	9.9	13.5	2.8	3.4	80-100	1.5	1.5	0.7	0.7
0-100	17.4	22.0	3.8	5.0					
0-80.5	10.5		2.7		80.5-100	1.4		0.6	
0-73.6		10.9		2.8	73.6-100		2.4		1.1
0-70.2	6.6		2.4		70.2-100	2.4		0.9	
0-64.1		7.5		2.5	64.1-100		5.1		2.1
100-0						-2.4	-2.7	1.4	1.4

<b>VOLVO PENTA</b> <b>1500rpm/1800 rpm</b>	Document No	Issue Index
	<b>23466373</b>	<b>03</b>

<b>Cold start performance</b>		rpm	1500	1800
Time from start to stay within 0.5% of no load speed at ambient temperature:	20 °C	s	4.8	4.6
	5 °C	s	5.7	5.2

<b>Lubrication system</b>		rpm	25%	50%	75%	100%	110%
Lubricating oil consumption	Power setting 360 kW	liter/h	0.006	0.012	0.018	0.025	0.027
		US gal/h	0.002	0.003	0.005	0.007	0.007
	Power setting 400 kW	liter/h	0.007	0.014	0.020	0.027	0.030
		US gal/h	0.002	0.004	0.005	0.007	0.008
Oil system capacity including filters		liter	49				
		US gal	12.9				
Oil sump capacity:	max	liter	44				
		US gal	11.6				
	min	liter	35				
		US gal	9.2				
Oil change intervals/ specifications: (Fuel quality dependant)	VDS-3	h	600				
	VDS-2	h	400				
		h					
		h					
Engine angularity limits, static (ref. classification rules, roll and pitch simultaneously)	front up	°	36				
	front down	°	36				
	side tilt	°	36				

<b>Lubrication system</b>		rpm	1500	1800
Oil pressure at rated speed		kPa	360	450
		psi	52.2	65.3
Lubrication oil temperature in oil sump:	max	°C	110	
		°F	230	
Oil filter micron size		μ	40	

\* See also general section in the sales guide

<b>VOLVO PENTA</b> 1500rpm/1800 rpm	Document No	Issue Index				
	<b>23466373</b>	<b>03</b>				

<b>Fuel system</b>		<b>rpm</b>	<b>load</b>	<b>25%</b>	<b>50%</b>	<b>75%</b>	<b>100%</b>	<b>110%</b>	
Specific fuel consumption with:	Power setting 360 kW	g/kWh		221	198	190	190	190	
		lb/hph		0.359	0.322	0.308	0.308	0.308	
			<b>rpm</b>		<b>1800</b>				
	Power setting 400 kW	g/kWh		240	207	199	197	198	
lb/hph		0.388	0.336	0.323	0.319	0.320			
Fuel to conform to		ASTM-D975-No. 1 and 2-D, JIS KK 2204, EN 590 MDO-DMX and MDO-DMA (ISO8217)							
		<b>rpm</b>		<b>1500</b>					
System return flow	Power setting 360 kW	liter/h		46	45	44	44	44	
		US gal/h		12.2	11.9	11.6	11.6	11.6	
			<b>rpm</b>		<b>1800</b>				
	Power setting 400 kW	liter/h		49	49	48	47	47	
US gal/h		12.9	12.9	12.7	12.4	12.4			
		<b>rpm</b>		<b>1500</b>					
System supply flow	Power setting 360 kW	liter/h		70	88	105	126	134	
		US gal/h		18.5	23.2	27.7	33.3	35.4	
			<b>rpm</b>		<b>1800</b>				
	Power setting 400 kW	liter/h		78	99	120	141	152	
US gal/h		20.6	26.2	31.7	37.3	40.2			
		<b>rpm</b>		<b>1500</b>					
Normal fuel pressure (after filter)	Power setting 360 kW	kPa		552	542	530	516	512	
		psi		80.1	78.6	76.9	74.8	74.3	
			<b>rpm</b>		<b>1800</b>				
	Power setting 400 kW	kPa		595	583	573	559	557	
psi		86.3	84.6	83.1	81.1	80.8			

**Fuel system**

Fuel supply line max restriction	kPa	30.0
	psi	4.4
Fuel supply max pressure head (day tank, from CL)	m	2.0
	feet	6.6
Fuel supply line max suction head (from CL)	kPa	4.0
	psi	0.6
Fuel return line max restriction	kPa	20.0
	psi	2.9
Maximum allowable inlet fuel temp	°C	50
	°F	122

<b>VOLVO PENTA</b> 1500rpm/1800 rpm	Document No	Issue Index				
	<b>23466373</b>	<b>03</b>				

<b>Intake system</b>		<b>rpm</b>	<b>1500</b>				
		<b>load</b>	<b>25%</b>	<b>50%</b>	<b>75%</b>	<b>100%</b>	<b>110%</b>
Air consumption at: (+25°C and 100kPa)	Power setting 360 kW	m <sup>3</sup> /min	11.95	15.08	21	25.43	26.67
		cfm	422	533	742	898	942
		<b>rpm</b>	<b>1800</b>				
	Power setting 400 kW	m <sup>3</sup> /min	14.42	17.4	23.33	28.15	29.25
		cfm	509	614	824	994	1033
Max allowable air intake restriction including piping		kPa	6				
		psi	0.9				
Air filter type		Paper cartridge					
Air filter cleaning efficiency		%	98.5				

<b>Exhaust system</b>		<b>rpm</b>	<b>1500</b>				
		<b>load</b>	<b>25%</b>	<b>50%</b>	<b>75%</b>	<b>100%</b>	<b>110%</b>
Heat rejection to exhaust at:	Power setting 360 kW	kW	65	114	156	208	235
		BTU/min	3696	6455	8843	11846	13364
		<b>rpm</b>	<b>1800</b>				
	Power setting 400 kW	kW	83	138	193	243	277
		BTU/min	4697	7831	10953	13836	15753

<b>Exhaust system</b>		<b>rpm</b>	<b>1500</b>				
		<b>load</b>	<b>25%</b>	<b>50%</b>	<b>75%</b>	<b>100%</b>	<b>110%</b>
Exhaust gas temperature after turbine at:	Power setting 360 kW	°C	286	366	356	388	395
		°F	547	691	673	730	743
		<b>rpm</b>	<b>1800</b>				
	Power setting 400 kW	°C	287	377	395	410	459
		°F	549	711	743	770	858
Exhaust back pressure after turbocharger during test		kPa	12				
		psi	1.7				
Permitted exhaust back pressure after turbocharger		kPa	17				
		psi	2.5				

		<b>rpm</b>	<b>1500</b>				
		<b>load</b>	<b>25%</b>	<b>50%</b>	<b>75%</b>	<b>100%</b>	<b>110%</b>
Exhaust gas flow at: (temp and pressure after turbine at the corresponding power setting)	Power setting 360 kW	m <sup>3</sup> /min	22.7	33.4	44.4	54.7	63
		cfm	802	1180	1568	1932	2225
		<b>rpm</b>	<b>1800</b>				
	Power setting 400 kW	m <sup>3</sup> /min	27.4	37.9	49.7	58	68.3
		cfm	968	1338	1755	2048	2412

<b>VOLVO PENTA</b> 1500rpm/1800 rpm	Document No	Issue Index
	<b>23466373</b>	<b>03</b>

Cooling system, HT circuit, heat rejection		rpm		1500		100%		110%	
		load	25%	50%	75%	100%	110%	110%	
Heat rejection radiation from engine to surrounding at:	Power setting 360 kW	kW	4	4	5	5	5	5	
		BTU/min	227	227	284	284	284	284	
	Power setting 400 kW	rpm		1800					
		kW	4	4	5	5	5	5	
		BTU/min	227	227	284	284	284		

Cooling system, HT circuit, heat rejection		rpm		1500		100%		110%	
		load	25%	50%	75%	100%	110%		
Heat rejection to coolant at: (HT)	Power setting 360 kW	kW	66	105	132	170	187		
		BTU/min	3753	5971	7507	9668	10635		
	Power setting 400 kW	rpm		1800					
		kW	82	125	159	205	225		
		BTU/min	4663	7109	9042	11658	12796		

Cooling system, HT circuit, other data		rpm		1500		1800	
Coolant volume in engine with std. expansion tank	liter	38				Note! Expansion tank size to be calculated. Recomended. 15% of total coolant volume	
	US gal	10.04					
Max. additional coolant in HT system with std. expansion tank	liter						
	US gal						
Coolant pump	drive/ratio	1/1.5					
Coolant flow with fully open thermostat	l/s	1.53	3.6				
	US gal/s	0.40	0.95				
Nominal coolant pressure with standard system	kPa	183.0	225.0				
	psi	26.5	32.6				
Maximum external coolant system restriction, including piping	kPa	85	85				
	psi	12.3	12.3				
Thermostat	start to open	°C	82				
		°F	180				
	fully open	°C	92				
		°F	198				
Design point for box cooler, engine outlet temperature	°C	90					
	°F	194					
Coolant flow at design point	l/s	1.50	2.70				
	US gal/s	0.40	0.71				
Maximum static pressure head (expansion tank height + pressure cap setting)	kPa	85					
	psi	12.3					
Standard pressure cap setting	kPa	75					
	psi	10.9					
Maximum temperature entering engine	°C	60	70				
	°F	140	158				
Coolant (40% coolant / 60% water)	See operators Manual						

<b>VOLVO PENTA</b> 1500rpm/1800 rpm	Document No	Issue Index
	<b>23466373</b>	<b>03</b>

Cooling system, LT circuit, heat rejection		rpm		1500				
		load	25%	50%	75%	100%	110%	
Heat rejection to coolant at: (LT)	Power setting 360 kW	kW	10	20	47	71	74	
		BTU/min	569	1137	2673	4038	4208	
		rpm		1800				
		load	25%	50%	75%	100%	110%	
	Power setting 400 kW	kW	13	24	50	82	80	
		BTU/min	739	1365	2843	4663	4550	

**Cooling system, LT, other data**

Coolant volume in engine charge air cooler circuit	liter US gal	7 1.85	Note! Expansion tank size to be calculated. Recommended. 15% of total coolant volume
Max. additional coolant in LT system with std. expansion tank	liter US gal		
Maximum static pressure head (expansion tank height + pressure cap setting)	kPa psi	85 12.3	
Standard pressure cap setting	kPa psi	75 10.9	
LT circuit pump	drive/ratio	1/1.5	
		<b>rpm 1500 1800</b>	
Nominal LT water design flow	l/s	1.40	1.60
	US gal/s	0.37	0.42
Nominal LT water pump pressure head at design flow	kPa	86	88
	psi	12.5	12.8
Maximum LT waterpump suction head	kPa	-14	-19
	psi	-2.0	-2.8
Maximum additional pressure drop LT water circuit	kPa	105	107
	psi	15.2	15.5
Maximum allowed LT water circuit pressure before Heat Exchanger (External pump system)	kPa	72	65
	psi	10.4	9.4
Maximum temperature entering charge air cooler	°C	38	
	°F	100	
Coolant (40% coolant / 60%water)	See operators Manual		

<b>VOLVO PENTA</b> 1500rpm/1800 rpm	Document No	Issue Index				
	<b>23466373</b>	<b>03</b>				

<b>Charge air cooler system</b>		<b>rpm</b>	<b>load</b>	<b>25%</b>	<b>50%</b>	<b>75%</b>	<b>100%</b>	<b>110%</b>	
Cooling power	Power setting 360 kW	kW		10	20	47	71	74	
		BTU/min		569	1137	2673	4038	4208	
			<b>rpm</b>		<b>1800</b>				
	Power setting 400 kW	kW		13	24	50	82	80	
		BTU/min		739	1365	2843	4663	4550	
			<b>rpm</b>		<b>1500</b>				
Charge air mass flow	Power setting 360 kW	kg/s		0.24	0.3	0.42	0.5	0.5	
				<b>rpm</b>		<b>1800</b>			
	Power setting 400 kW	kg/s		0.29	0.35	0.47	0.56	0.56	
				<b>rpm</b>		<b>1500</b>			
	Charge air inlet temp. Charge air temp after turbo compressor)	Power setting 360 kW	°C		73	101	148	180	194
			°F		163	214	298	356	381
		<b>rpm</b>		<b>1800</b>					
Power setting 400 kW		°C		79	102	144	185	195	
		°F		174	216	291	365	383	
		<b>rpm</b>		<b>1500</b>					

<b>Charge air cooler system</b>		<b>rpm</b>	<b>load</b>	<b>25%</b>	<b>50%</b>	<b>75%</b>	<b>100%</b>	<b>110%</b>	
Charge air outlet temp. (Charge air temp after charge air cooler)	Power setting 360 kW	°C		31	35	38	40	48	
		°F		88	95	100	104	118	
			<b>rpm</b>		<b>1800</b>				
	Power setting 400 kW	°C		34	35	38	41	50	
		°F		93	95	100	106	122	
			<b>rpm</b>		<b>1500</b>				
Charge air pressure	Power setting 360 kW	kPa		260					
		psi		37.71					
			<b>rpm</b>		<b>1800</b>				
	Power setting 400 kW	kPa		241					
		psi		34.95					
			<b>rpm</b>		<b>1500</b>				

<b>VOLVO PENTA</b>	Document No	Issue Index
	<b>23466373</b>	<b>03</b>

**1500rpm/1800 rpm**

**Engine management system**

Functionality	Alternatives	Default setting
Governor mode	Isochronus/Droop	Droop
Governor droop	0/0, 1-5%	4%
Governor response	Adjustable PID (service tool)	0/0/0
Idle speed	600-1200	900
Fine speed adjustment	±90	0
Stop function	Normaly Closed/Normaly Opened	Depends on order

**Electrical system**

**rpm 1500 and 1800**

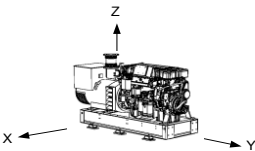
Voltage and type		24V / insulated from earth		
Alternator:	make/output	Amp	Bosch/110A	
	tacho output	Hz/alt. Rev	6	
	drive ratio		3.7:1	
Starter motor	make	Melco		
	type	105P70		
	kW	7.0		
Starter motor solenoid,	pull current	Amp	280	
	hold current	Amp	-	
Number of teeth on:	flywheel	153		
	starter motor	12		
Inrush current at +20°C \ 5°C		Amp	1020 \ 1560	
Cranking current at +20°C \ 5°C		Amp	400 \ 530	
Crank engine speed at 20°C \ 5°C		rpm	150 \ 130	
Starter motor battery capacity:	max	Ah	2x220	
	min at +5°C	Ah	2x180	
Max. g-force		x	m/s <sup>2</sup>	2
		y	m/s <sup>2</sup>	2
		z	m/s <sup>2</sup>	6

**VOLVO PENTA**

KC 360/400

1500rpm/1800 rpm

Document No

**23466373**

Issue Index

**03**

Sensors : Control and Monitoring System							Engine protection action
Sensors	Signal	Range	Unit	Warning Initial Delay / Warning Delay	Warning Level	Derating Level	
AUS/DEF concentration	Ultrasonic 1 Hz	0 - 62.5	%	N/A	<28	N/A	Warning only
AUS/DEF Tank Empty	Ultrasonic 1 Hz	0-100	%	30 sec	0	N/A	Warning only
AUS/DEF Tank Low level	Ultrasonic 1 Hz	0-100	%	30 sec	15	N/A	Warning only
AUS/DEF tank temp High alarm	Resistive	-40 - 125 ±1.5°C	°C	1 sec	70	N/A	Warning only
Coolant level switch	Digital	ON/OFF		30 sec from start / 11 sec	Low	N/A	Warning only
Coolant temperature	50-0 kΩ	-40 - 140 ±1.5°C	°C	30 sec from start / 2 sec	98	N/A	Warning only
Engine speed cam	Frequency		rpm	Instant	Lost signal	N/A	Warning only
Engine speed crank	Frequency		rpm	Instant	Lost signal	N/A	Warning only
Exhaust gas temperature after turbine	PT200	-40 - 750 ± 2.5%	°C	30 sec from start / 2 sec	532	N/A	Warning only
					N/A	N/A	Warning only
Oil level sensor	Digital	± 1.9 mm		30 sec from start / 5 sec	Low level	N/A	Warning only
Oil temperature	50-0 kΩ	-40 - 140 ± 1.5°C	°C	30 sec from start/1.5 sec	125	N/A	Warning only
Exhaust temperature before muffler	PT200	-40 - 750 ± 2.5%	°C	30 sec from start / 2 sec	532	N/A	Warning only
Water In fuel switch	Digital	ON/OFF		Instant	Water in fuel	N/A	Warning only
Wet Exhaust temp	PT200	0 - 850	°C	30 sec from start / 5 sec	192	N/A	Warning only

**VOLVO PENTA**

KC 360/400

1500rpm/1800 rpm

Document No

**23466373**

Issue Index

**03**

Sensors (rpm dependent)	Signal	Range	Unit	Initial Delay / Delay	Warning Level / Derating Level / Shutdown Level rpm Map				Comment
<b>Charge air pressure</b>	0,5-4,5 V	50-600 ±4.2 kPa	kPa				<b>1500 rpm</b>	<b>1800 rpm</b>	
Warning Level			kPa	30 sec from start / 2.2 sec			300	280	
Derating Level			kPa	NA			NA	NA	
<b>Charge air temperature</b>	50-0 kΩ	-40 - 130 ±4%	°C				<b>1500 rpm</b>	<b>1800 rpm</b>	
Warning Level			°C	60 sec from start / 15 sec			80	76	
Derating Level			°C	NA			NA	NA	
<b>Coolant pressure</b>	0,5-4,5 V	0-300±3%	kPa				<b>1500 rpm</b>	<b>1800 rpm</b>	
Warning Level			kPa	30 sec from start / 1.5sec			50	76	
Derating Level			kPa	NA			NA	NA	
<b>Fuel pressure</b>	0,5-4,5 V	0-700±2.5%	kPa				<b>1500 rpm</b>	<b>1800 rpm</b>	
Warning Level			kPa	60 sec from start / 5 sec			205	280	
Derating Level			kPa	NA			NA	NA	
<b>Oil pressure</b>	0,5-4,5 V	0-700±2.5%	kPa				<b>1500 rpm</b>	<b>1800 rpm</b>	
Warning Level			kPa	30 sec from start / 3 sec			260	260	
Derating Level			kPa	NA			NA	NA	
<b>Seawater pressure</b>	0,5-4,5 V	0-300±3%	kPa				<b>1500 rpm</b>	<b>1800 rpm</b>	Only HE and KC
Warning Level			kPa	30 sec from start / 5 sec			30	45	
Derating Level			kPa	NA			NA	NA	

Warning = Yellow Lamp active

Derating = Red Lamp active

# VOLVO PENTA

KC 360/400  
1500rpm/1800 rpm

Document No <b>23466373</b>	Issue Index <b>03</b>
--------------------------------	--------------------------

For SDM only

Sensors Control and Monitoring System											
Sensors	Signal	Range	Unit	Warning Initial Delay /	Shutdown level	Engine protection action					
Coolant temperature	Digital	ON/OFF ON= Shutdown	°C	12sec from start/1 sec	105	Shutdown					
Eng. overspeed SDM 1500+15%	Frequency	153 puls./rev	rpm / Hz	Instant	1725 rpm / 4399 Hz	Shutdown					
Eng. overspeed SDM 1800+15%	Frequency	153 puls./rev	rpm / Hz	Instant	2070 rpm / 5278 Hz	Shutdown					
Sensors (rpm dependent)	Signal	Range	Unit	Initial Delay / Delay	Warning Level / Derating Level / Shutdown Level					Engine protection action	
					0 rpm	600 rpm	1000 rpm	1500 rpm	1800 rpm		
Oil pressure <input type="checkbox"/>	Digital <input type="checkbox"/>	ON/OFF	kPa	12 sec from start / 1 sec	NA	120 ±20	120 ±20	120 ±20	120 ±20	Shutdown	

<b>VOLVO PENTA</b> KC 360/400 1500rpm/1800 rpm	Document No	Issue Index
	<b>23466373</b>	<b>03</b>

**Technical data - Exhaust AfterTreatment System data (EATS)****Weight data:**

SCR system weight: (incl SCR unit, AUS injector pipe, AUS sensor and bracket)			kg	115.7
			lb	255.1
Total SCR system weight for IPS: (incl SCR unit, AUS injector pipe, AUS sensor and bracket, exhaust piping)			kg	115.7
			lb	255.1
AUS pump			kg	3.1
			lb	6.8
AUS cabinet 20l weight: (incl tank, pump,UQS, ACM)			kg	36.4
			lb	80.2
AUS tank 160l weight:			kg	45
			lb	99.2
UQS - Lenght/Weight	mm	439	kg	1.2
	in	17.3	lb	2.6
UQS - Lenght/Weight	mm	597	kg	1.2
	in	23.5	lb	2.6
UQS - Lenght/Weight	mm	715	kg	1.3
	in	28.1	lb	2.9

**Dimension data:**

SCR Surface area		m2/ft2	2.2 / 23.7
SCR Flange:	Standard type		
	Diameter:	in/mm	6 in / 152 mm
	Number of Inlet / Outlet:	1 inlet / 2 outlet	

**Flow data:**

Max AUS flow to injector	l/h	7.9
	US gal/h	2.1
Max collant flow to AUS injector	l/h	6.7
	US gal/h	1.8

Exhaust system	Rating	rpm	600	800	1000	1200	1300	1400	1500	1600	1800	1900
Max allowable temperature drop between turbine and SCR muffler inlet.		°C							10		10	
		°F							50		50	
SCR muffler pressure drop at prop. load x <sup>3</sup>		kPa							3		5	
		psi							0.4		0.7	
SCR muffler pressure drop at Full load		kPa							6		7	
		psi							0.9		1.0	

<b>VOLVO PENTA</b> KC 360/400 1500rpm/1800 rpm	Document No	Issue Index
	<b>23466373</b>	<b>03</b>

AUS system	Rating	rpm	600	800	1000	1200	1300	1400	1500	1600	1800	1900
Specific AUS consumption		g/kWh							11.20		12.68	
		lb/hph							0.02		0.02	
AUS consumption at Full load		l/h							5.04		6.10	
		US gal/h							1.33		1.61	

AUS concentration 32.5%

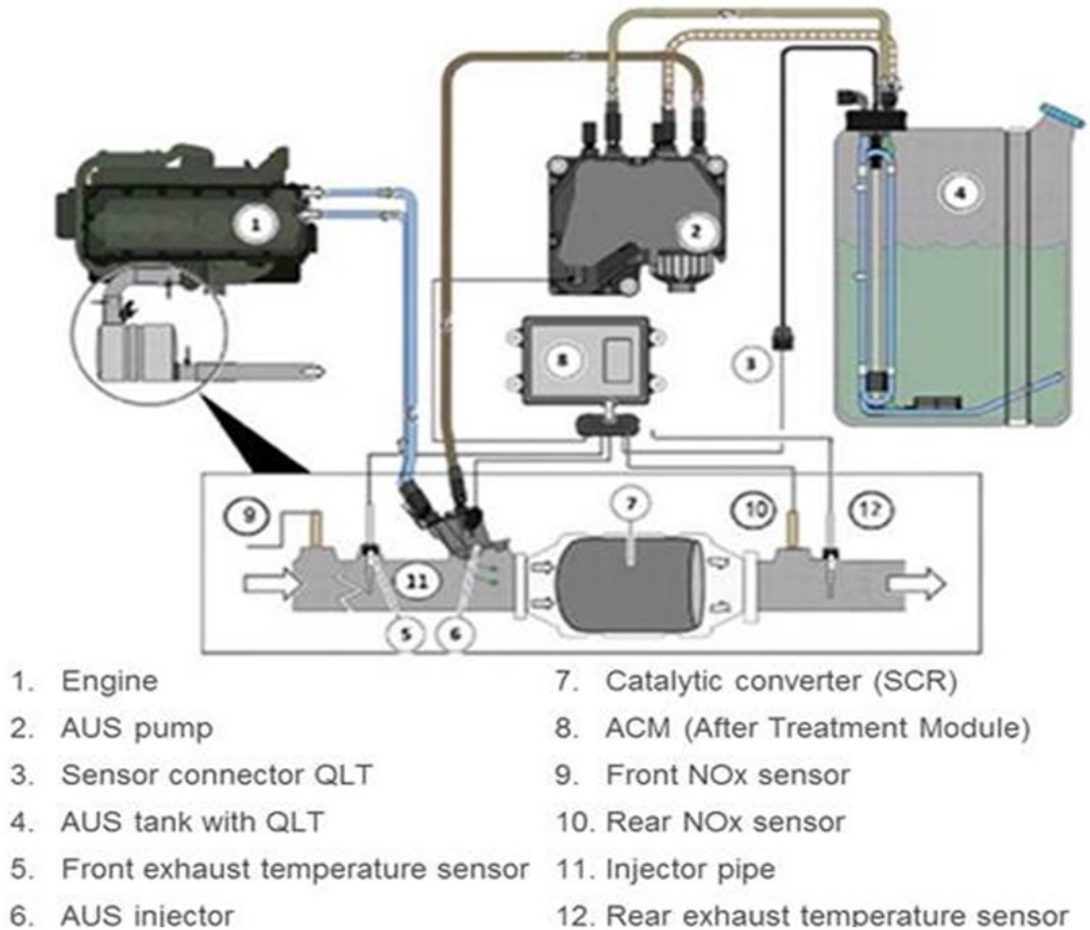

**Abbreviations:**

ACM	Aftertreatment Control Module
AUS	Aqueous Urea Solution
EATS	Exhaust Aftertreatment System
SCR	Selective Catalytic Reduction
UDS	Urea Dosing System
UQS	Urea Quality Sensor

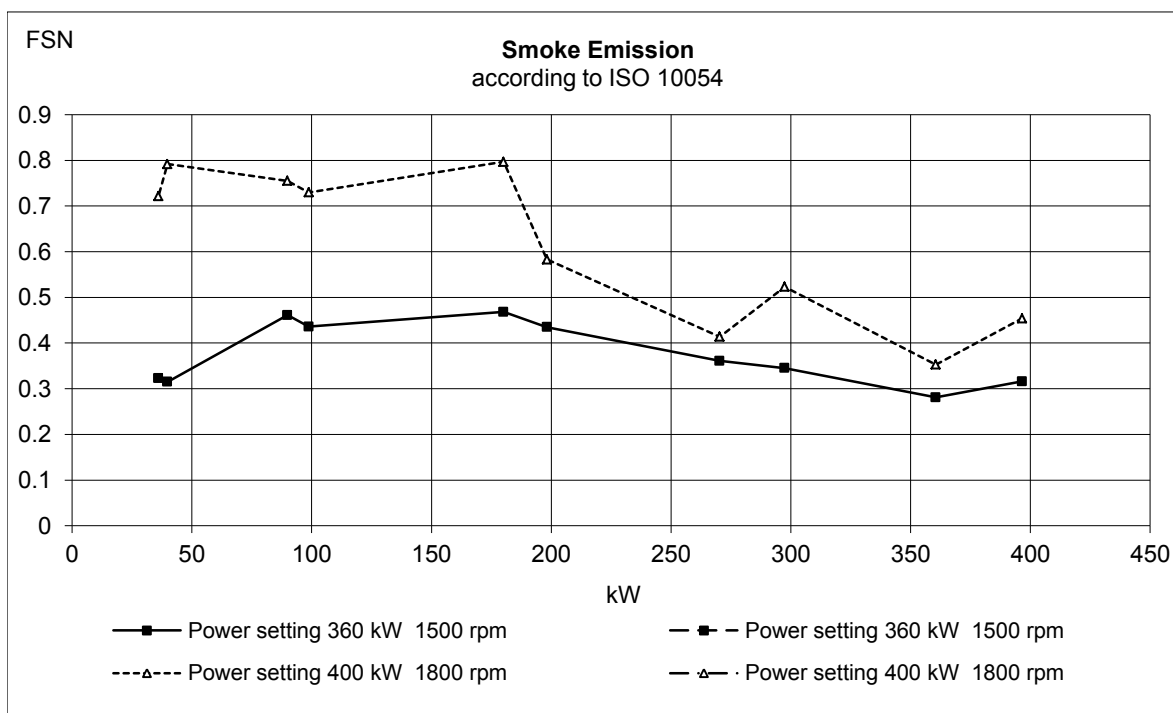
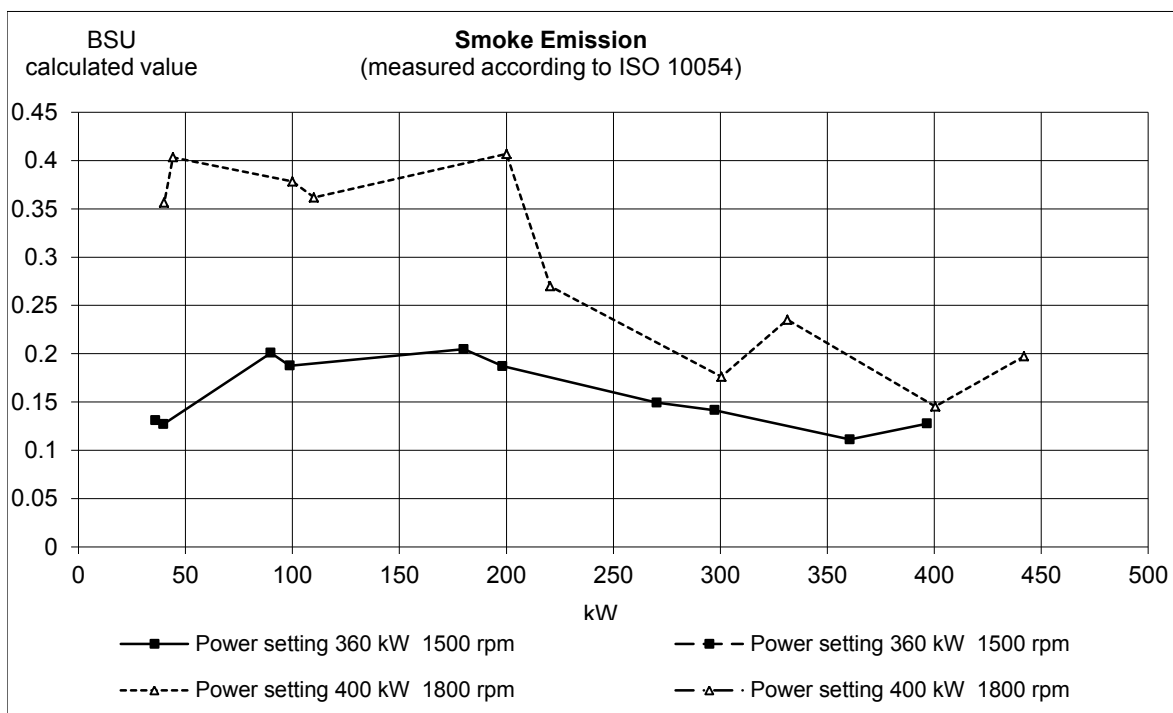

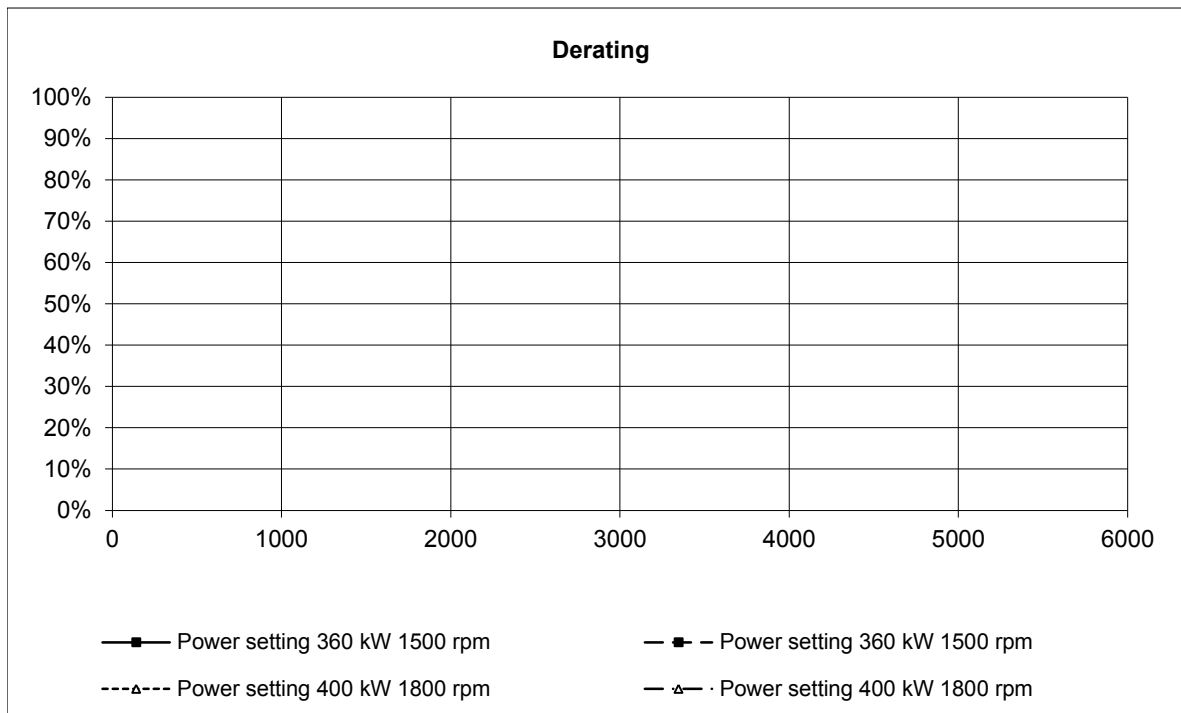
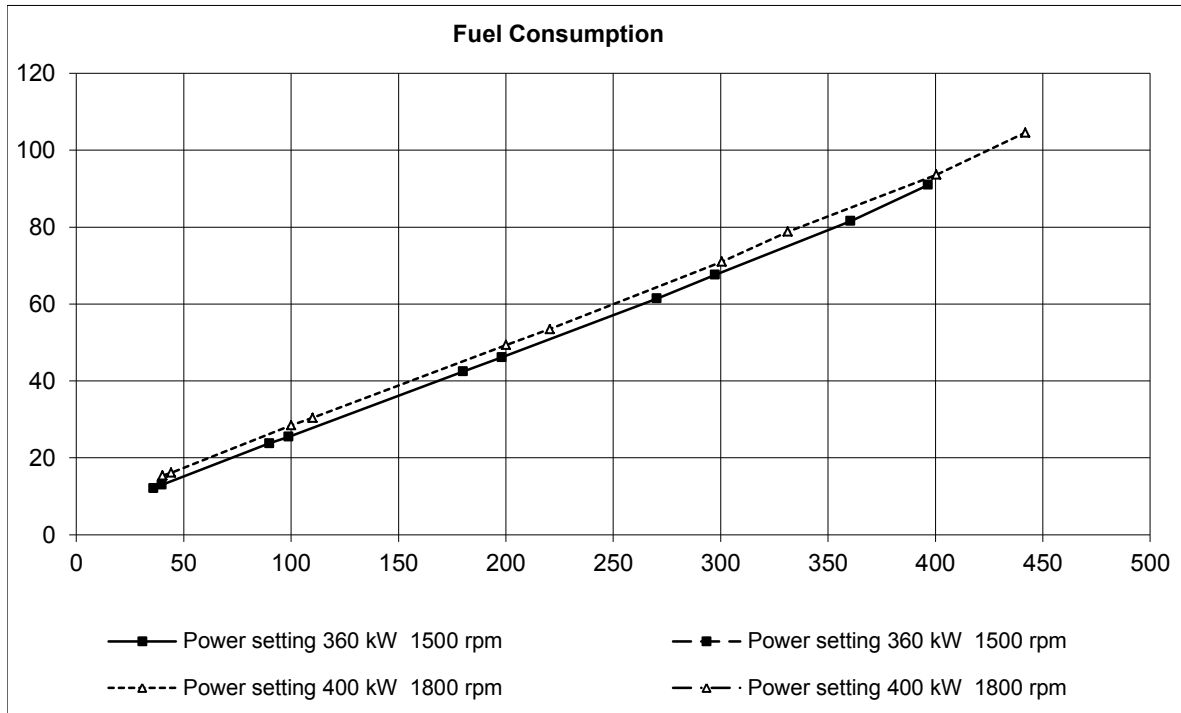

**VOLVO PENTA**

1500rpm/1800 rpm

Document No

**23466373**

Issue Index

**03**

