

Base on water temp 38°C/100°F

General

In-line four stroke diesel engine with direct injection. Rotation direction, anti-clockwise viewed towards flywheel. Turbocharged

Number of cylinders		6	
Displacement, total	litre in ³	16,12 983,9	
Firing order		1-5-3-6-2-4	
Bore	mm in	144 5,67	
Stroke	mm in	165 6,50	
Compression ratio		17,5:1	
Dry weight	Engine only, excluding cooling system	kg lb	1750 3858
	Genset, see dimension drawing	kg lb	

Performance		r/min	1500				
		load	25%	50%	75%	100%	110%
Power setting 450 kW		kW hp	113 153	225 306	338 459	450 612	495 673
Torque at:	Power setting 450 kW	Nm lbft	716 528	1432 1056	2149 1585	2865 2113	3151 2324
Mean piston speed		m/s ft/sec	8,3 27,1				
Effective mean pressure at:	Power setting 450 kW	MPa psi	0,6 81	1,1 162	1,7 243	2,2 324	2,5 356
Max combustion pressure at:	Power setting 450 kW	MPa psi	8,7 1262	10,7 1552	13,1 1900	15,8 2292	17,6 2553
Total mass moment of inertia, J (mR ²) Engine only		kgm ² lbft ²	4,70698 111,7				
Degree of irregularity at:	Power setting 450 kW		1;353	1;131	1;71	1;48	1;43
Friction Power		kW hp	42 57	42 57	42 57	42 57	42 57

Performance		load	25%	50%	75%	100%	110%
Power setting 500 kW		kW hp	125 170	250 340	375 510	500 680	550 748
Torque at:	Power setting 500 kW	Nm lbft	663 489	1326 978	1989 1467	2653 1956	2918 2152
Mean piston speed		m/s ft/sec	9,9 32,6				
Effective mean pressure at:	Power setting 500 kW	MPa psi	0,5 75	1,0 150	1,6 225	2,1 300	2,3 330
Max combustion pressure at:	Power setting 500 kW	MPa psi	8,9 1291	11,2 1624	13,9 2016	16,6 2408	18,2 2640
Total mass moment of inertia, J (mR ²) Engine only		kgm ² lbft ²	4,70698 111,7				
Degree of irregularity at:	Power setting 500 kW		1;295	1;264	1;134	1;88	1;79
Friction Power		kW hp	59 80,24	59 80,24	59 80,24	59 80,24	59 80,24

Engine noise emission

Test Standards: ISO 3744-1981 (E) sound power (without intake and exhaust noise)

Tolerans ± 0.75 dB(A)

		r/min		1500		1800	
		load	25%	50%	75%	100%	110%
Measured sound power Lw	No load	dB(A)			111,1		
	Power setting 450 kW	dB(A)	112,9	114,4	114,9	115,9	116,4
		r/min	1800				
Measured sound power Lw	No load	dB(A)			113		
	Power setting 500 kW	dB(A)	113,8	115,4	116	116,5	116,7

Unsilenced exhaust noise

Data calculated as sound pressure Lp.

Assumed microphone distance 1 m

		r/min		1500		1800	
		load	25%	50%	75%	100%	110%
Power setting 450 kW	dB(A)	109	112	114	115	116	
		r/min	1800				
Power setting 500 kW	dB(A)	113	116	118	119	120	

Vibrations (vibration velocity)

Declared vibration levels according to ISO 8528-9

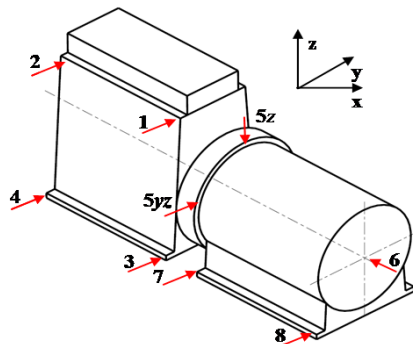

Measuring position	r/min		
	1500		
	RMS Velocity (10 - 1000Hz) Measurement direction		
	Axial [x] mm/s	Transverse [y] mm/s	Vertical [z] mm/s
1	8,3	12	8
2	7,3	14	12
3	7,1	12	9,7
4	7,5	10	13
5	8,5	20	12
6	7,1	13	8,9
7	7,7	15	16
8	8,1	16	16
	r/min		
	1800		
1	10	13	14
2	8,7	26	25
3	8,1	15	13
4	6,5	25	25
5	6,4	27	15
6	9,0	19	15
7	7,9	17	23
8	8,7	20	24

Test conditions for load acceptance data

Warm engine.	Generator	Modell	Type of AVR
	Stamford	HCM 534F	MX-341

Load acceptance performance can vary due to actual alternator inertia, voltage regulator, type of load and local ambient conditions.

Single step load performance at 1500 rpm

Load (%)	Speed diff (%)		Recovery time (s)		Remaining load (%)	Speed diff (%)		Recovery time (s)	
	Nominal	110% power	Nominal	110% power		Nominal	110% power	Nominal	110% power
0-40	5,1	5,5	1,1	2,2	40-100	9,9	11,2	2,7	4,1
0-50	7,4	9,3	2,3	2,5	50-100	6,8	7,5	2,4	3,3
0-60	11,4	15,1	2,7	3,3	60-100	5,0	5,5	2,1	2,9
0-x	10,0		2,5		x-100	5,2		2,2	
0-x		10,0		2,5	x-100		7,3		3,9
100-0	7,1	10,0	1,2	1,6					

Single step load performance at 1800 rpm

Load (%)	Speed diff %		Recovery time (s)		Remaining load (%)	Speed diff (%)		Recovery time (s)	
	Nominal	110% power	Nominal	110% power		Nominal	110% power	Nominal	110% power
0-20	2,2	2,5	0,9	1,1	20-100	12,2	16,0	2,4	7,0
0-40	3,6	4,2	1,2	1,2	40-100	5,9	6,8	1,2	6,0
0-60	6,9	8,6	1,9	1,6	60-100	3,6	4,2	1,3	2,2
0-70	9,2	12,3	1,8	2,6	70-100	2,9	3,0	1,2	1,7
0-x	10,0		1,9		x-100	2,8		1,1	
0-x		10,0		2,0	x-100		3,6		1,9
100-0	8,1	8,3	2,0	2,0					

Cold start performance

	20°C	s	1500	1800
Time from start to no load speed at ambient temperature:	20°C	s	5,8	6,7
	5 °C	s	6,0	7,1
Time from start to stay within 0.5% of no load speed at ambient temperature:	20°C	s	5,8	6,7
	5 °C	s	6,0	7,1

Block heater type	Make	Power kW	Engaged hours	Cooling water temp engine block
Ext./Thermostat-ctrl	Volvo Penta	2	12	32°C 90°F

Lubrication system		r/min load	25%	50%	1500	100%	110%
Lubricating oil consumption	Power setting 450 kW	liter/h				0,100	0,110
		US gal/h				0,026	0,029
	Power setting 500 kW	liter/h				0,110	0,120
		US gal/h				0,029	0,032
Oil system capacity including filters		liter	55				
		US gal	14,5				
Oil sump capacity:	max	liter	49				
		US gal	12,9				
min		liter	39				
		US gal	10,3				
Oil change intervals/ specifications: (Fuel quality dependant)	VDS-2. ACEA: E3, E5. API: CG-4, CH4	h	400				
	VDS. ACEA: E2. API: CF, CF-4	h	500				
		h					
		h					
Engine angularity limits, static (ref. classification rules, roll and pitch simultaneously)	front up	°	10				
	front down	°	10				
	side tilt	°	22,5				
Engine angularity limits, dynamic (ref. classification rules, roll and pitch simultaneously)	front up	°	15				
	front down	°	15				
	side tilt	°	22,5				

Lubrication system

	r/min load	1500	1800
Oil pressure at rated speed	kPa	425	440
	psi	62	64
Oil pressure shut down switch setting	kPa	200	200
	psi	29	29
Lubrication oil temperature in oil sump:	max	°C	128
		°F	262
Oil filter micron size	μ	40	

* See also general section in the sales guide

Fuel system	r/min load	25%	50%	1500	100%	110%
-------------	------------	-----	-----	------	------	------

VOLVO PENTA D16 MG 1800/1500 rpm	Document No	Issue Index
	21188254	03

Specific fuel consumption with:	Power setting 450 kW	g/kWh	229	208	203	206	202
		lb/hph	0,371	0,337	0,329	0,334	0,327
		r/min	1800				
	Power setting 500 kW	g/kWh	241	212	209	213	209
		lb/hph	0,391	0,344	0,339	0,345	0,339
		r/min	1500				
Fuel to conform to		ASTM-D975-No. 1 and 2-D, JIS KK 2204, EN 590 DMX and MDO-DMA (ISO8271)					
		r/min	1500				
System return flow	Power setting 450 kW	liter/h	47	47	47	47	47
		US gal/h	12,4	12,4	12,4	12,4	12,4
		r/min	1800				
	Power setting 500 kW	liter/h	51	51	51	51	51
		US gal/h	13,5	13,5	13,5	13,5	13,5
		r/min	1500				
System supply flow	Power setting 450 kW	liter/h	78	103	129	158	166
		US gal/h	20,6	27,2	34,1	41,7	43,9
		r/min	1800				
	Power setting 500 kW	liter/h	87	115	145	178	188
		US gal/h	23,0	30,4	38,3	47,0	49,7
		r/min	1500				
Normal fuel pressure (after filter)	Power setting 450 kW	kPa	455	449	445	438	437
		psi	66,0	65,1	64,5	63,5	63,4
		r/min	1800				
	Power setting 500 kW	kPa	478	475	472	466	466
		psi	69,3	68,9	68,5	67,6	67,6
		r/min	1500				

Fuel system

Fuel supply line max restriction	kPa	10
	psi	1,5
Fuel supply max pressure head (day tank, from CL)	m	2
	feet	6,6
Fuel supply line max suction head (from CL)	kPa	2
	psi	0,3
Fuel return line max restriction	kPa	20
	psi	2,9
Maximum allowable inlet fuel temp	°C	60
	°F	140

		r/min	1500				
Fuel system		load	25%	50%	75%	100%	110%
Fuel temp rise over engine	Power setting 450 kW	°C	27	27	27	27	27
		°F	81	81	81	81	81
		r/min	1800				
	Power setting 500 kW	°C	32	32	32	32	32
		°F	90	90	90	90	90
		r/min	1500				
Prefilter / Water separator micron size	μ	10					
Fuel filter micron size	μ	2					
		r/min	1500		1800		
Governor type/make, standard	Electronic/Volvo EMSII		Electronic/Volvo EMSII				
Injection pump type/make	Unit injector		Unit injector				
Injection timing std.	°B.T.D.C						
Injection timing	°B.T.D.C						

Intake system		r/min load	25%		50%		1500	
			75%	100%	110%			
Air consumption at: (+25°C and 100kPa)	Power setting 450 kW	m ³ /min cfm	15,23 538	20,52 725	26,95 952	32,92 1163	34,03 1202	
		r/min	1800					
	Power setting 500 kW	m ³ /min cfm	19,82 700	26,9 950	34,68 1225	40,57 1433	41,37 1461	
Max allowable air intake restriction including piping		kPa psi	3 0,4					
Air filter type		Paper cartridge						
Air filter cleaning efficiency		%	98					

Exhaust system		r/min r/min	25%		50%		1500	
			75%	100%	110%			
Heat rejection to exhaust at:	Power setting 450 kW	kW BTU/min	99 5630	174 9895	248 14104	328 18653	349 19847	
		r/min	1800					
	Power setting 500 kW	kW BTU/min	116 6597	193 10976	272 15468	372 21155	399 22691	

Exhaust system		r/min load	25%		50%		1500	
			75%	100%	110%			
Exhaust gas temperature after turbine at:	Power setting 450 kW	°C °F	326 619	408 766	436 817	467 873	476 889	
		r/min	1800					
	Power setting 500 kW	°C °F	299 570	355 671	382 720	436 817	454 849	
Max allowable back pressure in exhaust line		kPa psi	15 2,2					
Exhaust gas flow at: (temp and pressure after turbine at the corresponding power setting)	Power setting 450 kW	m ³ /min cfm	31,27 1104	47,23 1668	62,43 2205	76,12 2688	79,02 2791	
		r/min	1800					
	Power setting 500 kW	m ³ /min cfm	38,45 1358	56,58 1998	73,52 2596	88,9 3140	92,35 3261	

Cooling system		r/min load	25%		50%		1500	
			75%	100%	110%			
Heat rejection radiation from engine to surrounding at:	Power setting 450 kW	kW BTU/min	1 57	5 284	10 569	16 910	21 1194	
		r/min	1800					
	Power setting 500 kW	kW BTU/min	3 171	7 398	12 682	18 1024	23 1308	
Heat rejection to raw water system at:	Power setting 450 kW	kW BTU/min	81 4606	143 8132	215 12227	315 17914	324 18426	
		r/min	1800					
	Power setting 500 kW	kW BTU/min	121 6881	188 10691	278 15810	381 21667	409 23259	

Cooling system. Fresh water coolant circuit

Coolant volume engine, including heat exchanger, charge air cooler and std. expansion tank	liter	56	
	US gal	14,79	
Max. additional coolant for cabin heater etc. with std. expansion tank	liter	6	
	US gal	1,59	
Coolant pump	drive/ratio	1:1,906	
	r/min	1500	1800
Coolant flow with fully open thermostat	l/m	N/A	N/A
	US gal/m		
Nominal coolant pressure with standard system	kPa	75	75
	psi	10,9	10,9
Thermostat	start to open	°C	86
		°F	187
	fully open	°C	96
		°F	205
Maximum static pressure head (expansion tank height + pressure cap setting)	kPa	100	
	psi	14,5	
Standard pressure cap setting	kPa	75	
	psi	10,9	
Coolant (40% coolant / 60% water)	Volvo Penta coolant together with clean fresh water		

Cooling system. Engine mounted raw water pump

Raw water pump	drive/ratio	1:1,31	
	r/min	1500	1800
Nominal raw water design flow	l/m	378,0	438,0
	US gal/m	99,9	115,7
Nominal raw water pump pressure head at design flow (measured before and after pump)	kPa	80	100
	psi	11,6	14,5
Maximum raw water pump suction head	kPa	30	30
	psi	4,4	4,4
Maximum additional pressure drop (after heat exchanger)	kPa	26	33
	psi	3,8	4,8
Maximum raw water temperature entering heat exchanger	°C	38	
	°F	100	

Cooling system. Raw water circuit central cooling

	r/min	1500	1800
Maximum raw water flow	l/m	558,0	
	US gal/m	147,4	
Minimum raw water flow	l/m	378,0	438,0
	US gal/m	99,9	115,7
Pressure drop engine raw water circuit at maximum flow	kPa	100	
	psi	14,5	
Pressure drop engine raw water circuit at minimum flow	kPa	53	70
	psi	7,7	10,2
Maximum allowed raw water circuit pressure before heat exchanger (external pump system)	kPa	400	
	psi	58,0	
Maximum raw water temperature entering heat exchanger	°C	38	
	°F	100	

Charge air cooler system		r/min load	1500					
			25%	50%	75%	100%	110%	
Cooling power	Power setting 450 kW	kW	6,2	22,1	49,1	82,4	90,4	
		BTU/min	353	1257	2792	4686	5141	
			r/min	1800				
	Power setting 500 kW	kW	12,1	36,4	73,3	113,7	121,8	
BTU/min		688	2070	4168	6466	6927		
		r/min	1500					
Charge air mass flow	Power setting 450 kW	kg/s	0,300	0,404	0,530	0,645	0,667	
				r/min	1800			
	Power setting 500 kW	kg/s	0,390	0,528	0,680	0,794	0,810	
				r/min	1500			

Charge air cooler system		r/min load	1500					
			25%	50%	75%	100%	110%	
Charge air inlet temp. (Charge air temp after turbo compressor)	Power setting 450 kW	°C	63	101	142	182	190	
		°F	145	214	288	360	374	
			r/min	1800				
	Power setting 500 kW	°C	75	116	160	202	210	
		°F	167	241	320	396	410	
			r/min	1500				
		r/min	1800					

Charge air cooler system		r/min load	1500					
			25%	50%	75%	100%	110%	
Charge air outlet temp. (Charge air temp after charge air cooler)	Power setting 450 kW	°C	43	47	51	55	56	
		°F	109	117	124	131	133	
			r/min	1800				
	Power setting 500 kW	°C	44	48	53	60	61	
		°F	111	118	127	140	142	
			r/min	1500				
Charge air pressure	Power setting 450 kW	kPa	218					
		psi	31,62					
			r/min	1800				
	Power setting 500 kW	kPa	235					
psi		34,08						
Standard charge air cooler core area		m ²	0,04					
		foot ²	0,43					

Engine management system

Functionality	Alternatives	Default setting
Governor mode	Isochronous/Droop Switchable during operation	Droop
Governor droop	0-5%	0,0
Governor response	P, I and D via VODIA	
Idle speed	600-1200rpm	900rpm
Fine speed adjustment	N/A	±120rpm
Stop function	Energized to run / stop	Energized to stop

Engine protection		Alarm level	
Parameter	Unit	Setting range	Default setting
Oil temp	°C	N/A	125
Oil pressure	Low idle	kPa	N/A
	1500 rpm	kPa	N/A
	1800 rpm	kPa	N/A
Oil level		N/A	Low level
Piston cooling pressure >1000 rpm	kPa	N/A	150+/-20
Coolant temp	°C	95-103	98
Coolant level		N/A	Low level
Fuel feed pressure	Low idle	kPa	N/A
	>1400 rpm		N/A
Water in fuel		N/A	Water in fuel
Crank case pressure	kPa	N/A	Inc pressure
Charge air temp	°C	N/A	80
Charge air pressure	kPa	N/A	400
Engine speed	rpm	100-120% of rated speed	120%

Note! Complete sensor list available

Electrical system

r/min 1500 and 1800

Voltage and type		24V / insulated from earth	
Alternator:	make/output	A	Bosch 20849349/35-80A
	tacho output	Hz/alt. Rev	6
	drive ratio		4
Starter motor	make		Melco
	type		24V/7kW
	kW		7/kW
Starter motor solenoid,	pull current	A	2
	hold current	A	N/A
Number of teeth on:	flywheel		153
	starter motor		12
Inrush current at +20°C \ +5°C		A	2000 \ 2100
Cranking current at +20°C \ +5°C		A	375 \ 390
Crank engine speed at 20°C \ +5°C		rpm	165 \ 140
Starter motor battery capacity:	max	Ah	2x220 700A DIN
	min at +5°C	Ah	2x180 600A DIN
Max. g-force	x	m/s ²	
	y	m/s ²	
	z	m/s ²	

