

<b>VOLVO PENTA</b>	Document No	Issue Index
	<b>23609270</b>	<b>03</b>

**D6-340 AQ****General**

4-stroke direct injected, turbocharged and aftercooled diesel engine

Engine Rating		4
Number of cylinders		6
No of valves		24
Displacement, total	litres in <sup>3</sup>	5.50 335.6
Firing order		1-5-3-6-2-4
Rotational direction, viewed from the front		Clockwise
Bore	mm in	103 4.06
Stroke	mm in	110 4.33
Compression ratio		18.0:1
Compression pressure at 240 rpm	MPa psi	
Max. static forward inclination:	°	5
Max. static backward inclination:	°	10
Max. intermittent forward inclination while running:	°	10
Max. intermittent backward inclination while running:	°	20
Max. intermittent side inclination while running:	°	22.5 or 30 for max 30 sec
Idling speed	rpm	600-650
Rated speed R4	rpm	3400
Governed speed R4	rpm	3530
Propeller selection range R4		3350-3530
Dry weight engine BT	kg lb	610 1345
Dry weight with drive DPI	kg lb	755 1664
Dry weight with drive DPH	kg lb	745 1642
	kg lb	
	kg lb	

- 1) ISO 3046, fuel temp 40°C.  
ISO 8665 (=SAE J 1228=ICOMIA 28-83)
- 2) At power according to 1).
- 4) Acc. to ISO 3744
- 5) At installed back pressure

<b>VOLVO PENTA</b>	Document No	Issue Index
	<b>23609270</b>	<b>03</b>

**D6-340 AQ**

Performance	rpm	1000	1500	2000	2500	2800	3000	3200	3300	3400	3500
		Crankshaft power 1), 5)	kW	48	99	182	228	250	250	250	250
	hp	65	135	248	310	340	340	340	340	340	340
Propeller shaft power 1) (At full load)	kW	46	95	175	219	240	240	240	240	240	240
	hp	63	129	238	298	326	326	326	326	326	326
Propellershaft power at prop. load x <sup>2.5</sup>	kW	11	31	64	111	148	176	206	223	240	241
	hp	15	42	87	151	201	239	280	303	326	327
Propellershaft power at prop. load x <sup>3</sup>	kW	6	21	49	95	134	165	200	219	240	241
	hp	8	28	66	130	182	224	272	298	326	327
Torque at crankshaft 2)	Nm	458.4	630.3	869	870.9	852.6	795.8	746	723.4	702.2	682.1
	lbf ft	338	465	641	642	629	587	550	534	518	503
Mean piston speed	m/s	3.7	5.5	7.3	9.2	10.3	11.0	11.7	12.1	12.5	12.8
	ft/s	12.0	18.0	24.1	30.1	33.7	36.1	38.5	39.7	40.9	42.1
Effective mean pressure 2)	MPa	1.05	1.44	1.99	1.99	1.95	1.82	1.70	1.65	1.60	1.56
	psi	151.9	208.9	288.0	288.6	282.6	263.7	247.3	239.8	232.7	226.1
Max combustion pressure 2)	MPa	12.7	16.5	18.7	18.7	17.6	16.4	15.3	15.0	14.9	15.1
	psi	1842	2392	2713	2714	2559	2384	2222	2180	2164	2194

**Lubricating system**

Specific lubricating oil consumption.	g/kWh	< 0.2
Max. oil volume including filters for all allowed installation inclinations:	litres	20
	US gal	5.28
Max. oil volume excluding filters for all allowed installation inclinations:	litres	18.5
	US gal	4.89
Min. oil volume excluding filters for all allowed installation inclinations:	litres	15
	US gal	3.96

Fuel system	rpm	1000	1500	2000	2500	2800	3000	3200	3300	3400	3500
Specific fuel consumption 2)	g/kWh	254	248	212	201	203	209	220	223	228	230
	lb/hph	0.411	0.402	0.343	0.326	0.329	0.339	0.356	0.361	0.369	0.373
Fuel consumption, Test cycle E5 EU	g/kWh	225									
	lb/hph	0.36									
Fuel consumption at prop. load x <sup>2.5</sup>	l/h	3.6	8.6	17.0	29.2	39.5	47.2	58.0	63.4	68.4	69.0
	US gal/h	1.0	2.3	4.5	7.7	10.4	12.5	15.3	16.7	18.1	18.2

Fuel system	rpm	1000	1500	2000	2500	2800	3000	3200	3300	3400	3500
Fuel consumption at prop. load x <sup>3</sup>	l/h	2.5	6.3	13.5	25.5	36.3	44.6	56.3	62.3	68.2	69.0
	US gal/h	0.7	1.7	3.6	6.7	9.6	11.8	14.9	16.4	18.0	18.2
Fuel consumption at full load	l/h	14.6	29.4	46.2	54.8	60.7	62.5	65.8	66.7	68.2	68.8
	US gal/h	3.9	7.8	12.2	14.5	16.0	16.5	17.4	17.6	18.0	18.2

**Full load performance at rated speed**

Fuel inlet temperature	°C	40
	°F	104
Fuel return temperature from engine	°C	64
	°F	147.2
Fuel consumption	l/h	70
	US gal/h	18.49
Fuel inlet flow to engine	l/h	107.4
	US gal/h	28.37
Fuel return flow from engine	l/h	37.4
	US gal/h	9.88

1) ISO 3046, fuel temp 40°C.

ISO 8665 (=SAE J 1228=ICOMIA 28-83)

2) At power according to 1).

4) Acc. to ISO 3744

5) At installed back pressure

<b>VOLVO PENTA</b>	Document No	Issue Index
	<b>23609270</b>	<b>03</b>

**D6-340 AQ**

Intake and exhaust system	rpm	1000	1500	2000	2500	2800	3000	3200	3300	3400	3500
Specific exhaust heating effect in percent of crankshaft power	%	49	55	53	50	52	56	62	65	69	68
Exhaust temperature at the exhaust pipe connecting flange after the turbo charger.	°C	372	471	443	365	352	345	352	357	365	357
	°F	702	880	829	689	666	653	666	675	689	675
Permitted exhaust back pressure after turbocharger at rated speed. (Installed back pressure)	kPa							Max	30		
	psi								4.4		
	kPa							Min	10		
	psi								1.5		

Intake and exhaust system	rpm	1000	1500	2000	2500	2800	3000	3200	3300	3400	3500
Engine air consumption at 25°C / 77°F atmospheric pressure 100kPA	m³/min	2.8	5.0	9.8	14.8	18.0	19.5	21.2	22.0	22.8	22.9
	cu.ft./min	98.88	176.6	346.1	522.7	635.7	688.6	748.7	776.9	805.2	808.7
Charge air pressure Inlet manifold	kPa	18	43	113	157	181	186	195	198	202	197
	psi	2.6	6.2	16.4	22.8	26.3	27.0	28.3	28.7	29.3	28.6
Exhaust gas flow	m³/min	6.7	13.9	24.5	30.8	35.2	36.8	39.3	40.5	41.8	41.4
	cu.ft./min	236.6	490.9	865.2	1088	1243	1300	1388	1430	1476	1462

Cooling system	rpm	1000	1500	2000	2500	2800	3000	3200	3300	3400	3500
Radiated heat of crankshaft power at full load.	kW	1.4	2.9	5.4	6.8	7.6	7.5	7.5	7.6	7.5	7.5
Heat rejection to charge air cooler of crankshaft power at full load.	kW	1.2	4.9	20.3	37.2	50.6	56.5	65.0	69.1	73.4	73.4
Coolant heat rejection to HE, incl. engine oil cooler and excl. charge air cooler, of crankshaft power at full load.	kW	51.1	95.7	143.2	138.4	162.9	157.5	164.7	181.9	170.3	173.4
Coolant flow with fully open thermostat and std cooling system	l/min	97	144	193	239	264	269	275	278	283	287
	cu.ft./min	3.4	5.1	6.8	8.4	9.3	9.5	9.7	9.8	10.0	10.1
Extra water pump flow through charge air cooler	l/min										
	cu.ft./min										
Max. pump pressure at extra pump pressure side (pressure set system)	kPa										
	psi										
Max. permissible temperature on coolant in engine outlet	°C	55									
	°F	131									
Coolant volume engine, including heat exchanger and charge air cooler	litres	16									
	US gal.	4.23									
Max. additional coolant for cabin heater etc. with std. Expansion tank	litres	5									
	US gal.	1.32									
Maximum coolant flow to cabin heater etc.	l/min	30									
	cu.ft./min	1.06									
Thermostat, start open at	°C	78									
	°F	172									
Thermostat, fully open at	°C	90									
	°F	194									

- 1) ISO 3046, fuel temp 40°C.  
ISO 8665 (=SAE J 1228=ICOMIA 28-83)
- 2) At power according to 1).
- 4) Acc. to ISO 3744
- 5) At installed back pressure

<b>VOLVO PENTA</b>	Document No	Issue Index
	<b>23609270</b>	<b>03</b>

**D6-340 AQ**

Raw water circuit	rpm	1000	1500	2000	2500	2800	3000	3200	3300	3400	3500
Nominal raw water design flow	l/min	77	111	144	174	189	198	207	211	214	218
	cu.ft./min	2.7	3.9	5.1	6.1	6.7	7.0	7.3	7.5	7.6	7.7
Nominal raw water pump pressure head at design flow.	kPa	26	51	81	116	137	150	162	169	175	181
	psi	3.8	7.4	11.7	16.8	19.9	21.8	23.5	24.5	25.4	26.3
Maximum raw water pump suction head	kPa	-30									
	psi	-4.4									
Maximum additional pressure drop excl. reverse gear oil cooler	kPa										
	psi										
Pressure drop over reverse gear oil cooler (optional equipment)	kPa										
	psi										
Maximum raw water temperature entering heat exchanger	°C	32									
	°F	90									

1 circuit keel cooling system	rpm	1000	1500	2000	2500	2800	3000	3200	3300	3400	3500
Design point for keel cooler, engine outlet temperature	°C										
	°F										
Maximum temperature to engine from external cooling system circuit	°C										
	°F										
Maximum temperature to engine inlet from external cooling system circuit	°C										
	°F										
Coolant flow through keel cooler at design point	l/min										
	cu.ft./min										
Maximum coolant flow through keel cooler	l/min										
	cu.ft./min										
Pressure drop in external circuit, including piping	kPa										
	psi										
Coolant volume engine	litres										
	US gal.										

1 1/2 circuit keel cooling system (Two circuit	rpm	1000	1500	2000	2500	2800	3000	3200	3300	3400	3500
Design point for keel cooler, engine outlet temperature	°C										
	°F										
Maximum temperature to charge air cooler from external cooling system circuit	°C										
	°F										
Coolant flow through keel cooler at design point	l/min										
	cu.ft./min										
Maximum coolant flow through keel cooler	l/min										
	cu.ft./min										
Pressure drop in external circuit, including piping	kPa										
	psi										
Coolant volume engine	litres										
	US gal.										

2 circuit keel cooling system, LT	rpm	1000	1500	2000	2500	2800	3000	3200	3300	3400	3500
Maximum temperature to charge air cooler from external LT-cooling system	°C										27
	°F										81
Coolant flow through keel cooler, LT-cooling system circuit	l/min										218
	cu.ft./min										7.7
Pressure drop in external LT-cooling system circuit, including piping	kPa	50									
	psi	7.3									
Coolant volume charge air cooler	litres	2									
	US gal.	0.53									

- 1) ISO 3046, fuel temp 40°C.  
ISO 8665 (=SAE J 1228=ICOMIA 28-83)
- 2) At power according to 1).
- 4) Acc. to ISO 3744
- 5) At installed back pressure

<b>VOLVO PENTA</b>	Document No	Issue Index
	<b>23609270</b>	<b>03</b>

**D6-340 AQ**

<b>2 circuit keel cooling system, HT</b>	<b>rpm</b>	<b>1000</b>	<b>1500</b>	<b>2000</b>	<b>2500</b>	<b>2800</b>	<b>3000</b>	<b>3200</b>	<b>3300</b>	<b>3400</b>	<b>3500</b>
Design point for keel cooler, engine outlet temperature	°C										83
	°F										181
Maximum temperature to engine from external HT-cooling system circuit	°C										60
	°F										140
Coolant flow through keel cooler, HT-cooling system circuit at design point	l/min										130
	cu.ft./min										4.6
Maximum coolant flow through keel cooler, HT-cooling system circuit	l/min										287
	cu.ft./min										10.1
Pressure drop in external HT-cooling system circuit, including piping	kPa	70									
	psi	10.2									
Coolant volume engine	litres	16									
	US gal.	4.23									

<b>Emissions</b>	<b>rpm</b>	<b>1000</b>	<b>1500</b>	<b>2000</b>	<b>2500</b>	<b>2800</b>	<b>3000</b>	<b>3200</b>	<b>3300</b>	<b>3400</b>	<b>3500</b>
Smoke at prop. load x <sup>2.5</sup>	*BSU	0.1	0.2	0.3	0.3	0.2	0.2	0.3	0.3	0.5	0.3
Smoke at prop. load x <sup>3</sup>	*BSU	0.1	0.1	0.3	0.3	0.2	0.2	0.3	0.3	0.5	0.3
Noise at prop. load x <sup>2.5</sup> . 4)	dBA	98.7	101.9	104.8	108.3	110.5	110.5	111.7	112	112.2	112.9
Noise at prop. load x <sup>3</sup> . 4)	dBA	97.7	101.8	104.3	107.5	111.6	110.3	111.5	111.9	112.3	112.7

\*NB.! BSU are calculated values. Measured values are acc. to ISO 10054 in FSN units

- 1) ISO 3046, fuel temp 40°C.  
ISO 8665 (=SAE J 1228=ICOMIA 28-83)
- 2) At power according to 1).
- 4) Acc. to ISO 3744
- 5) At installed back pressure

Document No	Issue Index
<b>23609270</b>	<b>03</b>

Sensors : Control and Monitoring System							Engine protection action
Sensors	Signal	Range	Unit	Warning Initial Delay / Warning Delay	Warning Level	Derating Level	
Coolant level switch	Digital	ON/OFF		30 sec from start / 5 sec	Low (ON / Closed)	NA	Warning only
Coolant temperature	50-0 kΩ	-40 - 140	°C	30 sec from start / 5 sec	96	99	See derating map
Fuel temperature	50-0 kΩ	-40 - 140	°C		60	NA	Warning only
Engine speed cam	Frequency		rpm	Instant	Lost signal	NA	Warning only
Engine speed crank	Frequency		rpm	Instant	Lost signal	NA	Warning only
Oil level sensor	Digital	ON/OFF		30 sec from start / 5 sec	Low level	NA	Warning only
Oil temperature	PT1000	-40 - 150	°C	30 sec from start / 5 sec	132	135	See derating map
Water In fuel switch	Digital	ON/OFF		All the time	Water in fuel	NA	Warning only
Wet Exhaust temp	PT200	0 - 850	°C	30 sec from start / 5 sec	90	95	See derating map

Sensors (rpm dependent)	Signal	Range	Unit	Initial Delay / Delay	Warning Level / Derating Level / Shutdown Level rpm Map					Comment
					0 rpm	1200 rpm	2000 rpm	2500 rpm	3600 rpm	
<b>Charge air temperature</b>	50-0 kΩ	-40 - 130	°C		<b>0 rpm</b>	<b>1200 rpm</b>	<b>2000 rpm</b>	<b>2500 rpm</b>	<b>3600 rpm</b>	
Warning Level			°C	30 sec from start / 5 sec	100	100	70	70	70	
Derating Level			°C							See derating map
<b>Fuel pressure</b>	0,5-4,5 V	0-200	kPa		<b>0 rpm</b>	<b>600 rpm</b>	<b>1600 rpm</b>	<b>2600 rpm</b>	<b>3600 rpm</b>	
Warning Level			kPa	30 sec from start / 5 sec	50	50	50	50	50	
Derating Level			kPa	NA	NA	NA	NA	NA	NA	
<b>Oil pressure</b>	0,5-4,5 V	0-700	kPa		<b>0 rpm</b>	<b>600 rpm</b>	<b>1200 rpm</b>	<b>2000 rpm</b>	<b>3600 rpm</b>	
Warning Level			kPa	30 sec from start / 5 sec	-50	75	150	200	230	
Derating Level (30% remain trq.)			kPa	10% trq. decr. per sec	-50	70	120	170	200	

Warning = Yellow Lamp active

Derating = Red Lamp active

## Derating map

<b>Charge Air Temp [°C]</b>	<b>rpm</b>	<b>75°C</b>	<b>80°C</b>	<b>85°C</b>
Remaining torque in %	600	100%	100%	100%
	1600	100%	100%	100%
	2200	100%	75%	50%

<b>Coolant temp [°C]</b>	<b>rpm</b>	<b>99°C</b>	<b>104°C</b>	<b>108°C</b>
Remaining torque in %	600	100%	100%	100%
	1600	100%	85%	75%
	2200	100%	75%	50%

<b>Oil temp [°C]</b>	<b>rpm</b>	<b>135°C</b>	<b>137.5°C</b>	<b>140°C</b>
Remaining torque in %	600	100%	100%	100%
	1600	100%	85%	75%
	2200	100%	75%	50%

<b>Oil pressure [kPa]</b>	<b>rpm</b>	
Remaining torque in %	600	85%
	1600	70%
	2200	50%

<b>Wet exhaust temp [°C]</b>	<b>rpm</b>	<b>95°C</b>	<b>105°C</b>	<b>115°C</b>	<b>125°C</b>
Remaining torque in %	600	100%	100%	100%	100%
	1600	100%	85%	80%	75%
	2200	100%	75%	65%	50%

Document No	Issue Index
<b>23609270</b>	<b>03</b>

Transmission: Control and Monitoring System: DPI Drive							Engine protection action
Sensors	Signal	Range	Unit	Warning Initial Delay / Warning Delay	Warning Level	Derating Level	
Gear oil temperature (EVC)	50-0 kΩ	-30 - 130±4%	°C	N/A	95		Warning only
Gear oil pressure (EVC)	Frequency	0-3000±3%	kPa	60 sec from start / 7 sec	700		Warning only

Transmission: Control and Monitoring System: Reverse Gear							Engine protection action
Sensors	Signal	Range	Unit	Warning Initial Delay / Warning Delay	Warning Level	Derating Level	
Gear oil temperature (EVC)	50-0 kΩ	-30 - 130±4%	°C	N/A	95		Warning only

Transmission: Control and Monitoring System: IPS Drive							Engine protection action
Sensors	Signal	Range	Unit	Warning Initial Delay / Warning Delay	Warning Level	Derating Level	
Gear oil temperature (EVC)	50-0 kΩ	-30 - 130±4%	°C	N/A	95		Warning only
Gear oil pressure (EVC)	Frequency	0-3000±3%	kPa	60 sec from start / 7 sec	700		Warning only

<b>VOLVO PENTA</b>	Document No	Issue Index
	<b>23609270</b>	<b>03</b>

D6-340 AQ

**Technical data - Drive unit**

Drive line		DPI with D4/D6
Transmission type		DPI-A
Gear ratio (total)		1,69:1 and 1,85:1
Steering angle, max.		+/- 24°
Total weight of drive unit (1)	kg	154
Oil capacity, approx.	litres	5.7
Oil volume difference MIN-MAX	litres	0.3
Oil type drive		Volvo Penta API GL5 75W/90
Propeller range		H2-H10

(1) Drive, Transom shield kit, including oil and various installation components. Propellers are not included in total weight

**"Generalized maximum load document"for DPI**

Valid products	Drive Unit	Gear Ratio
DPI-A with D6	DPI	1,69:1
DPI-A with D4	DPI	1,85:1

Loads provided in chart are single maximum loads i.e. not to be used for fatigue calculations

Speed range (top speed)	Load vektor	Maximum load
25-50 kn	Fx	18 kN
	Fy (+/-)	11 kN
	MCL rudder (+/-)	1.6 kNm

Fy load coordinate	570 mm
Fy load coordinate	330 mm

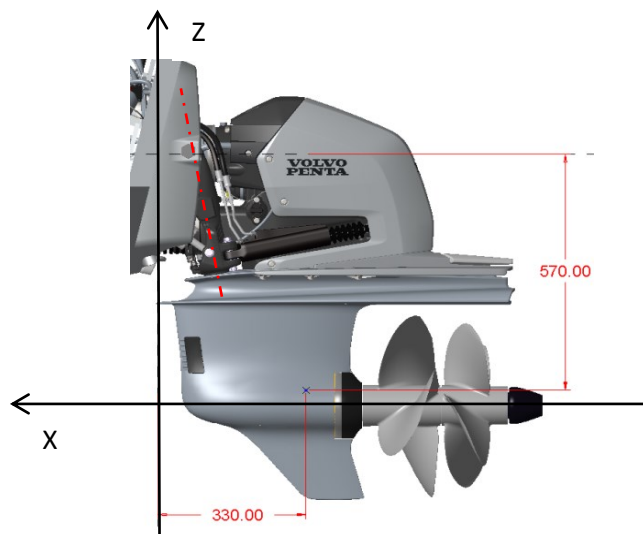

**VOLVO PENTA**

Document No

Issue Index

**D6-340 AQ**

**23609270**

**03**

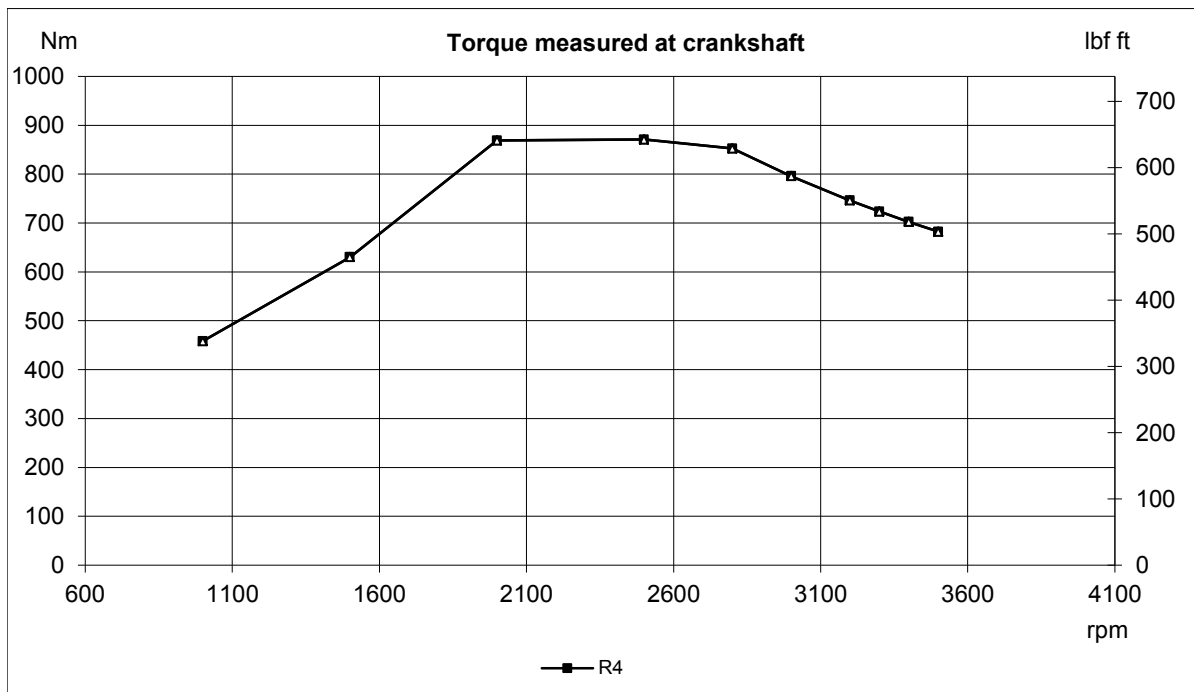
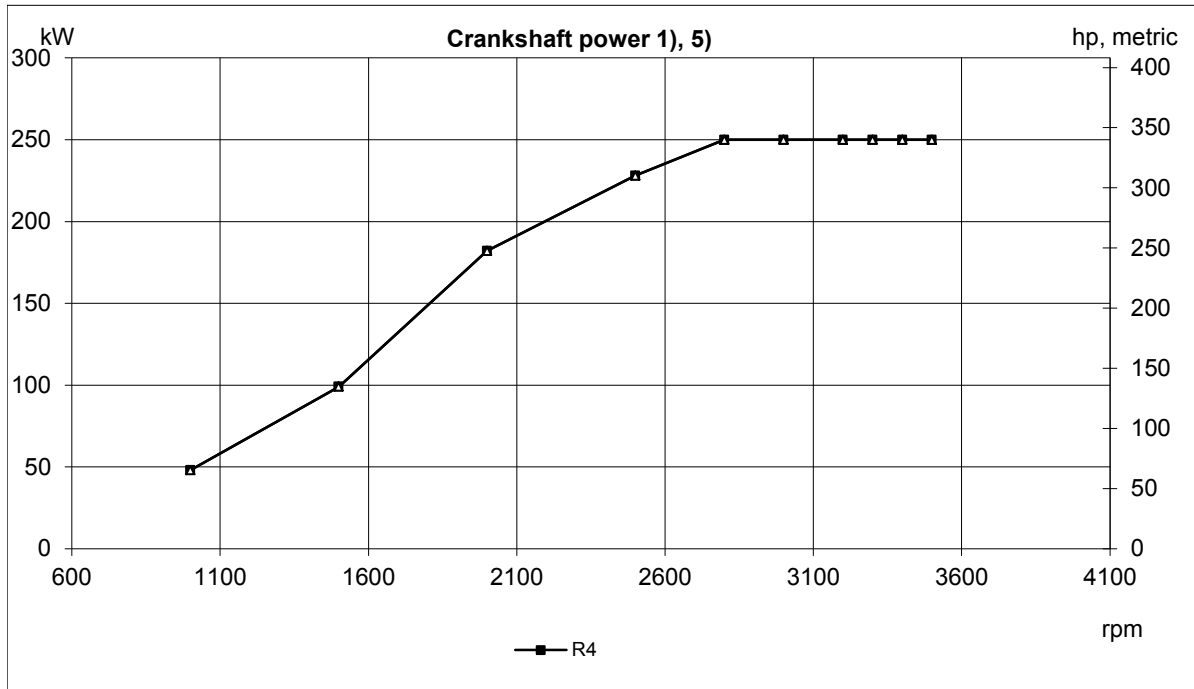

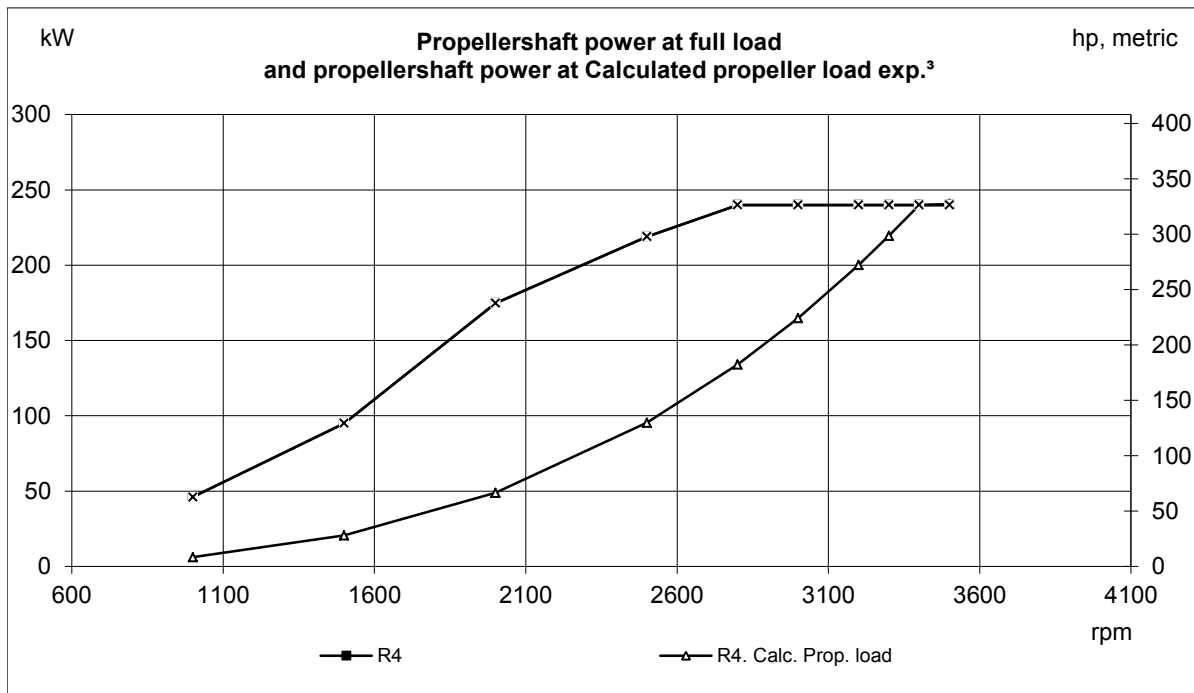
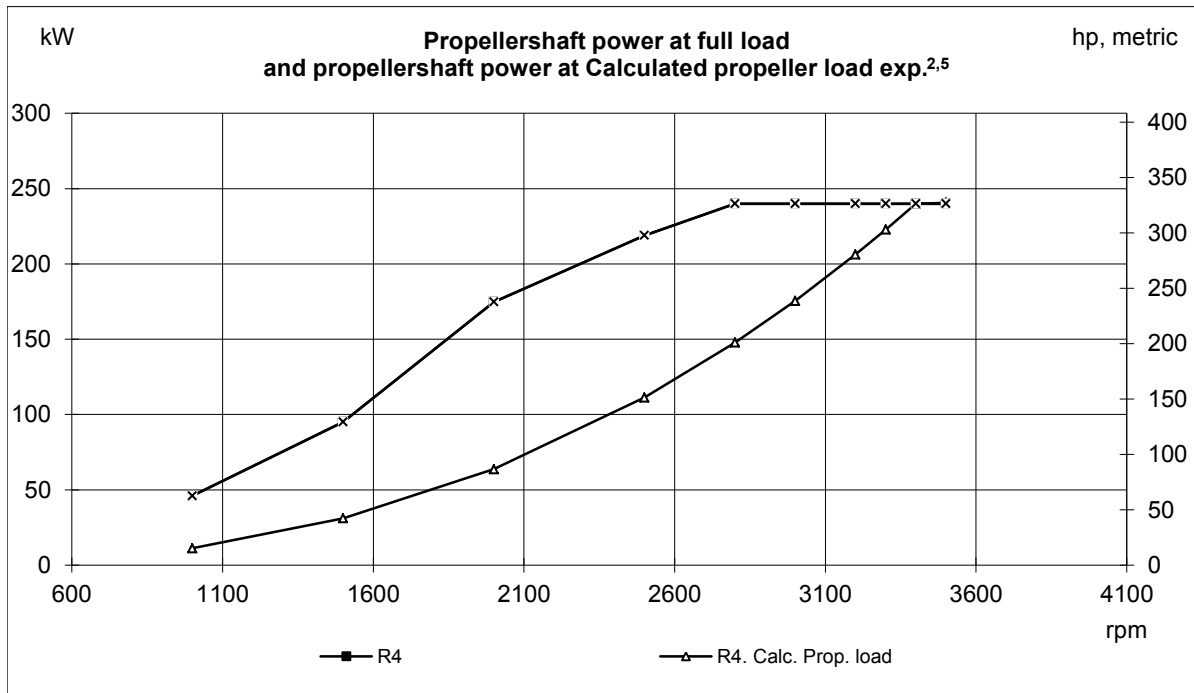

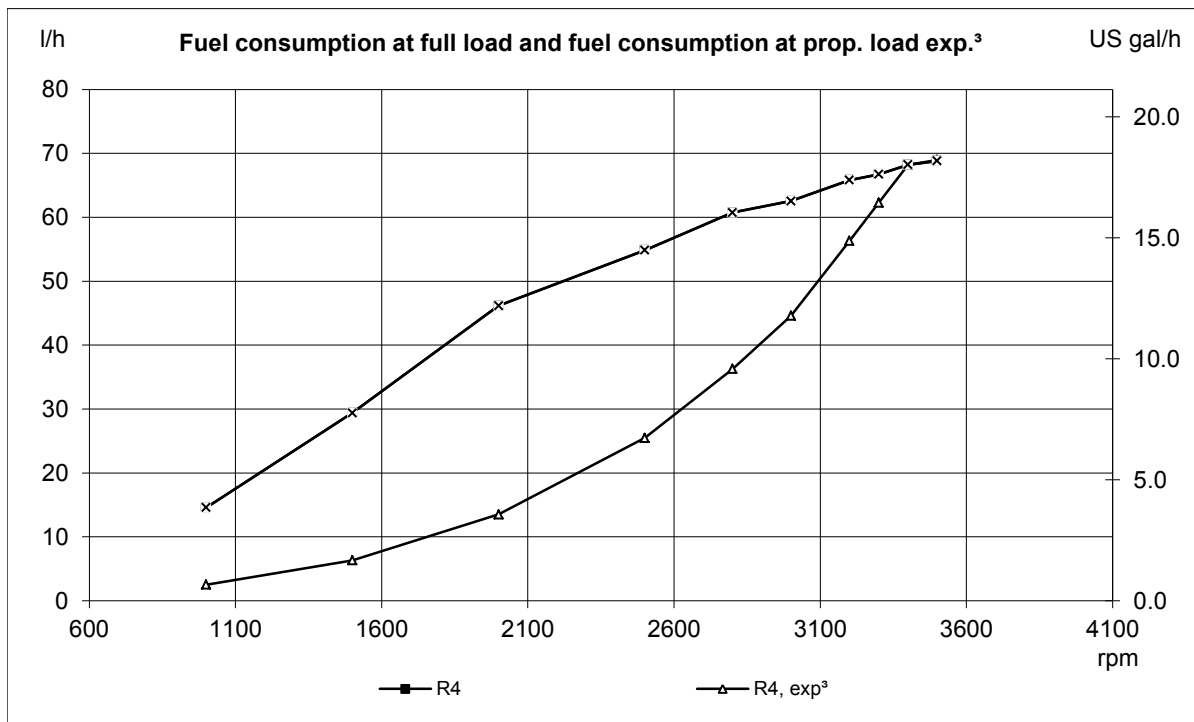
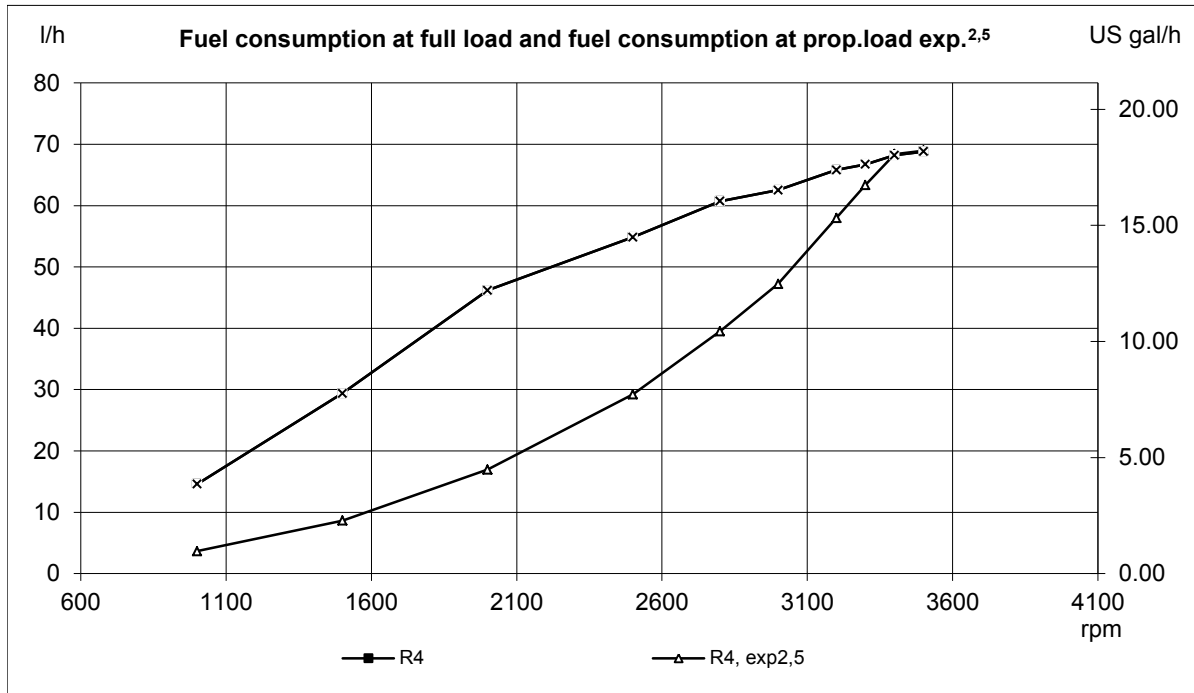

**VOLVO PENTA**

Document No

Issue Index

**D6-340 AQ**

**23609270**

**03**

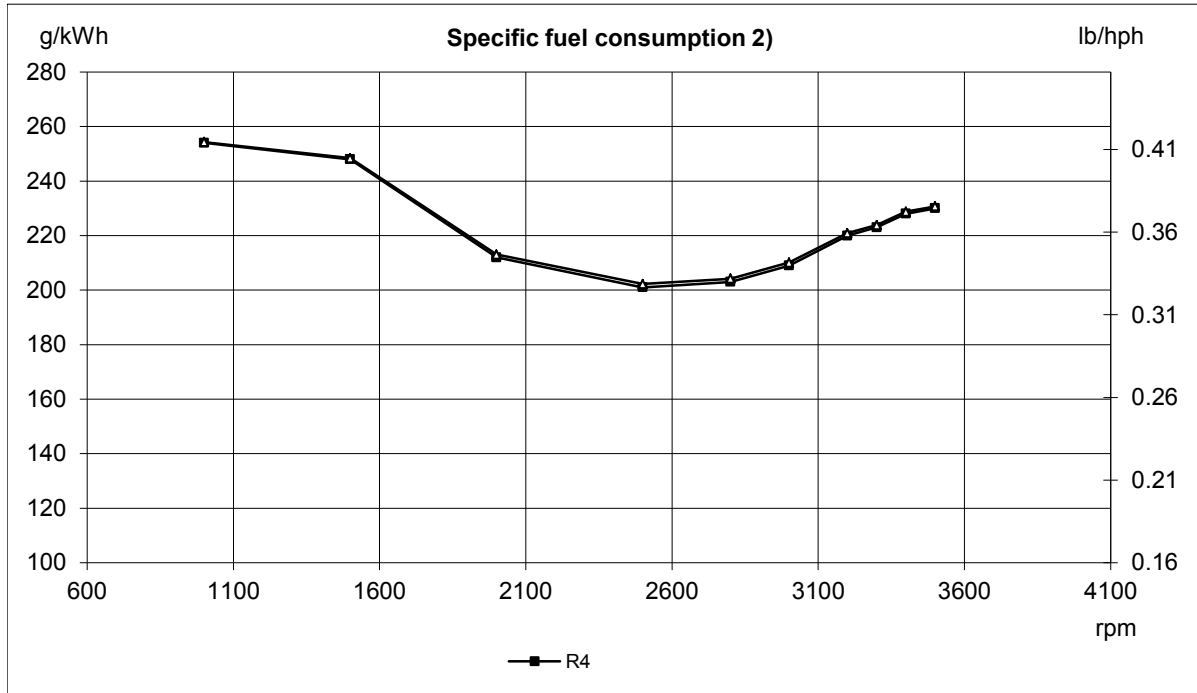

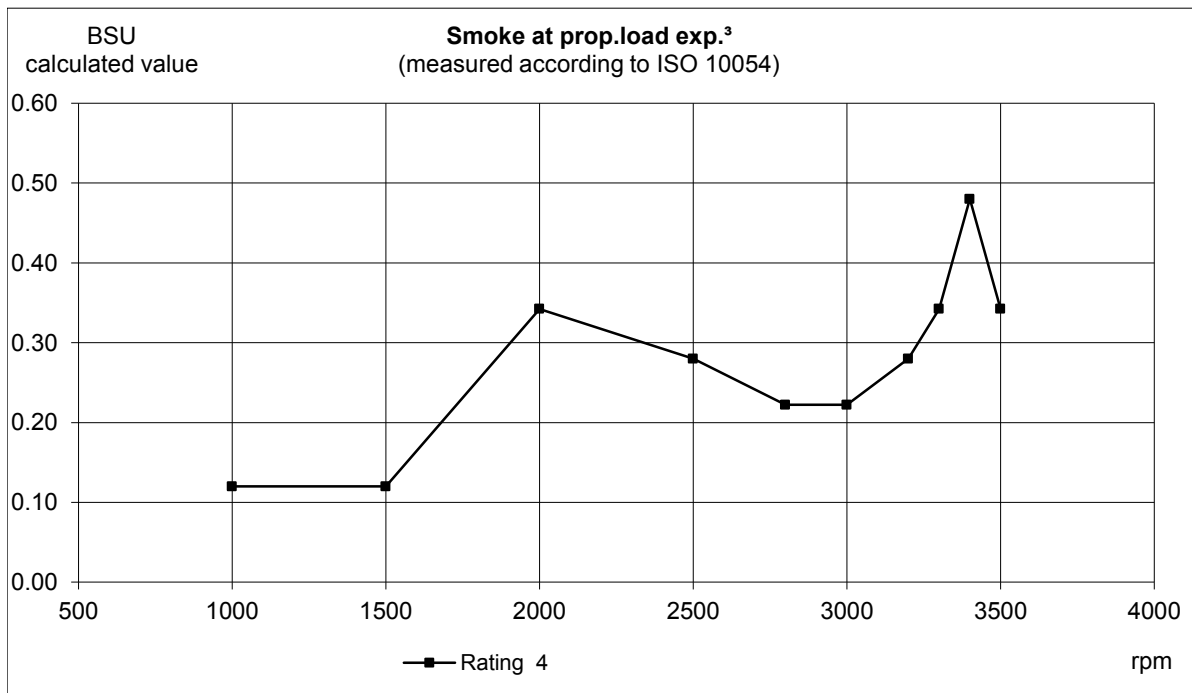
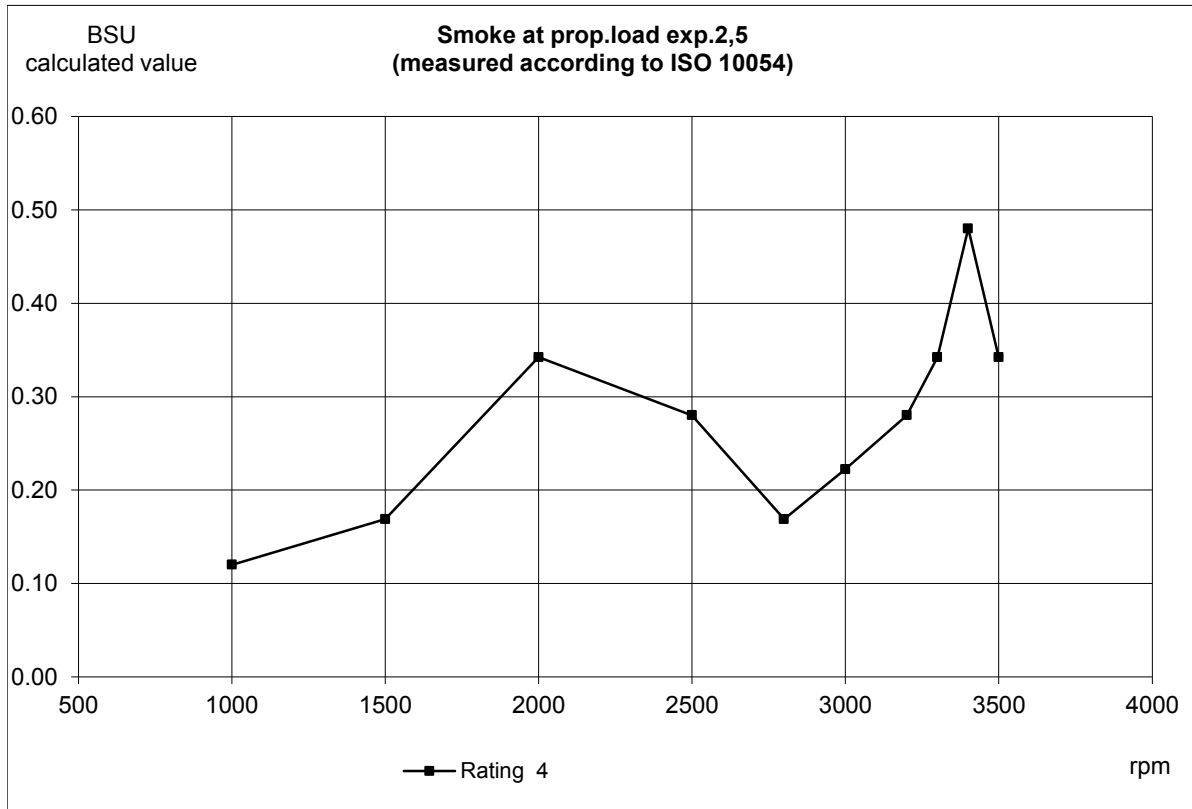

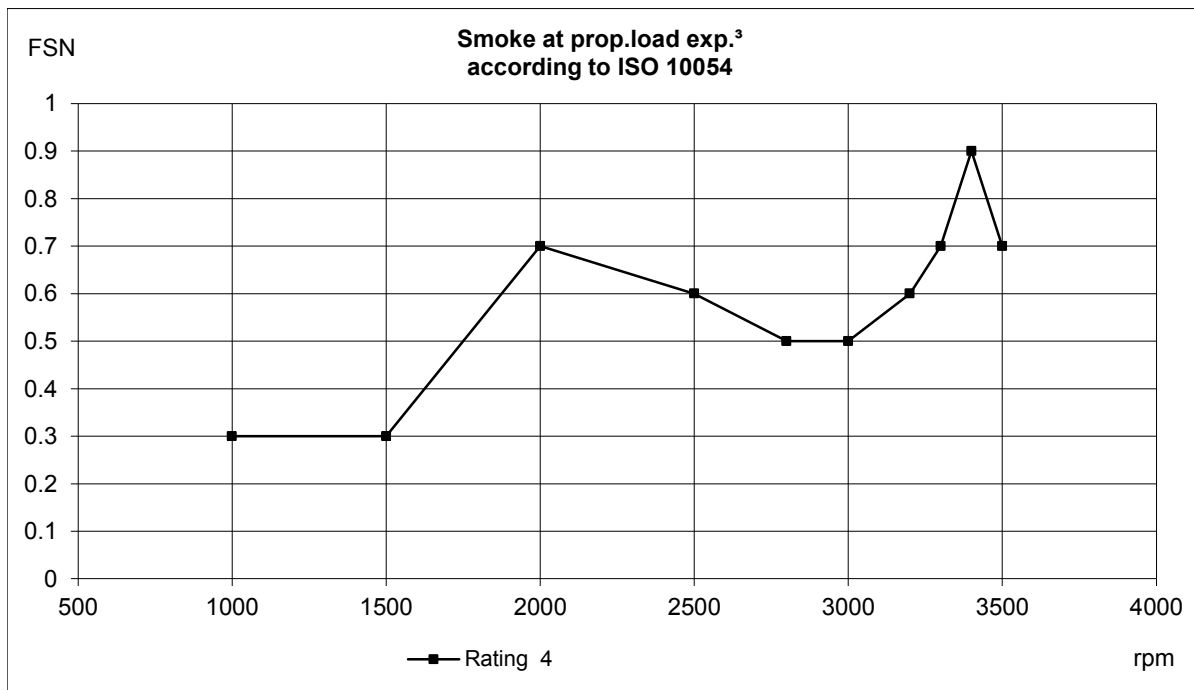
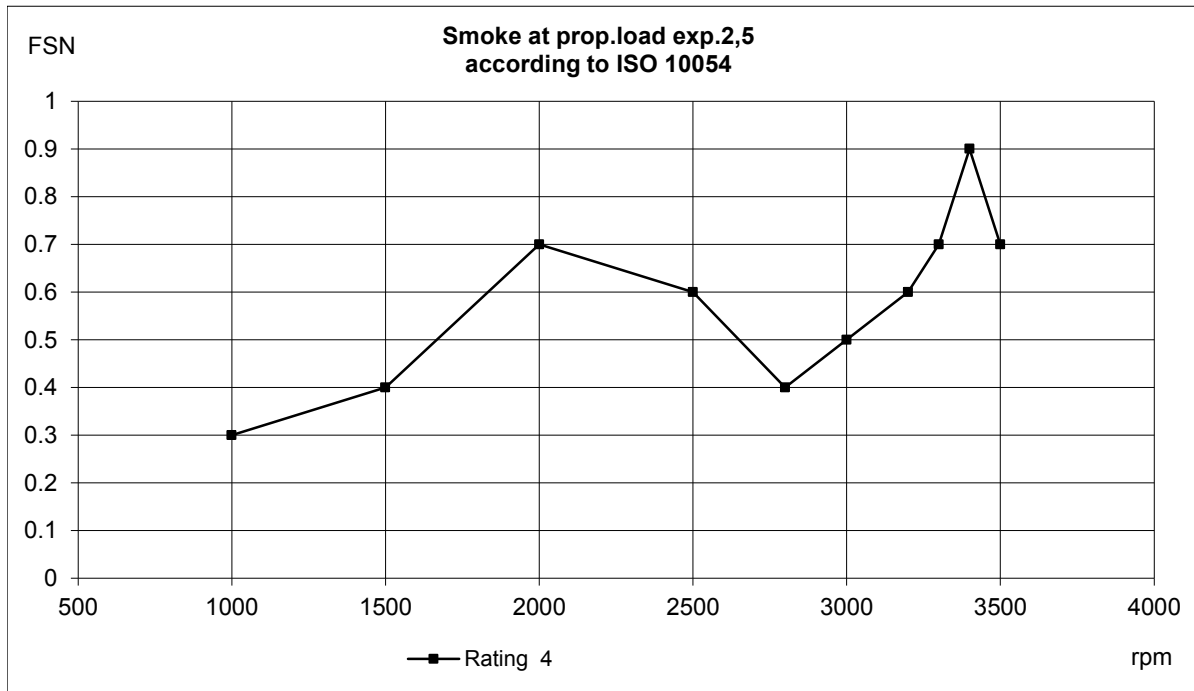

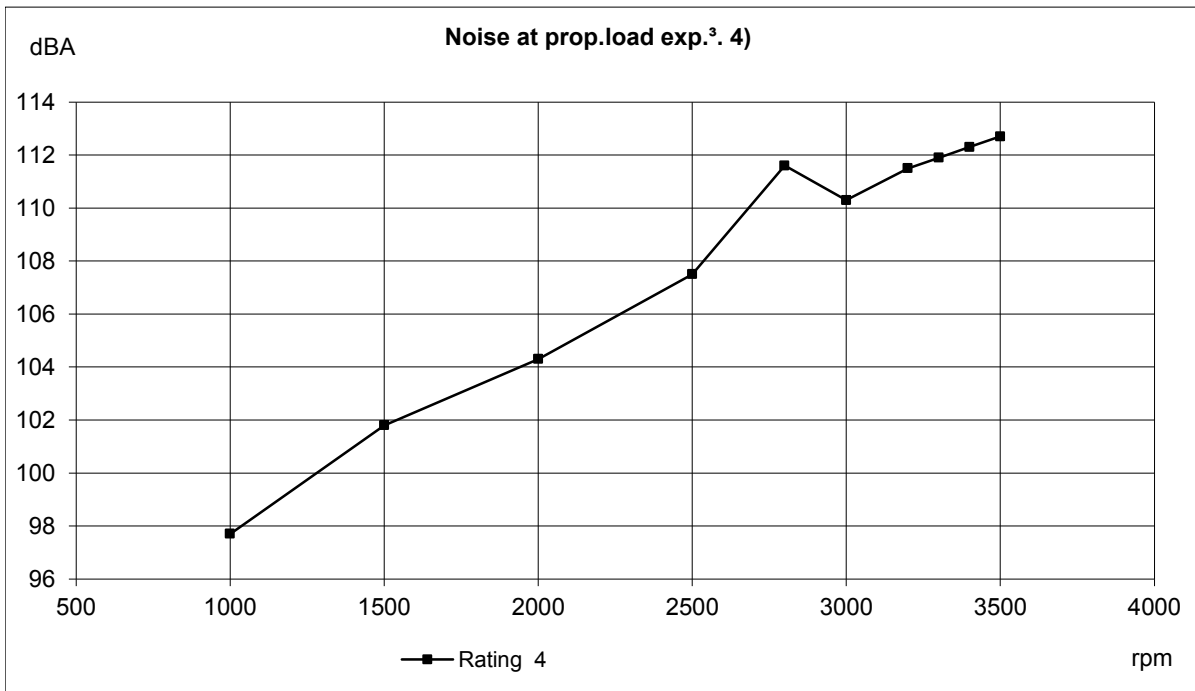
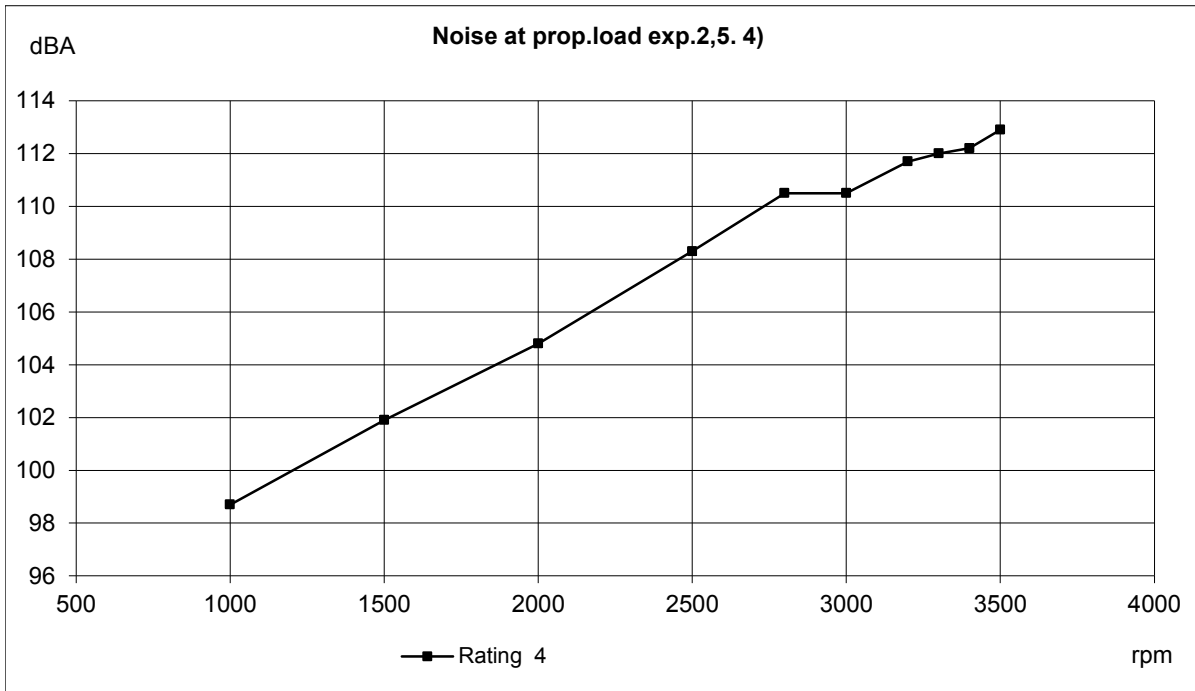

<b>VOLVO PENTA</b>	Document No	Issue Index
	<b>23609270</b>	<b>03</b>
<b>D6-340 AQ</b>		

**Battery capacity 12V DPI**

Temp	Min battery size	CCA EN (Cold cranking Amps)	Max line resistance @ 20°C	Recommended max cable resistance @ 20°C	Min cross sectional area (due to heat increase)
[°C]	[Ah]	[A]	[mΩ]	[mΩ]	[mm <sup>2</sup> ]
5	95	850 (EN)	2	1.8	70
-5	120	1150 (EN)	2	1.8	70

**Battery capacity 24V DPI**

5	75	750 (EN)	2	1.8	50
-5	95	850 (EN)	2	1.8	50

**Battery capacity 12V DPH**

5	95	750 (EN)	2	1.8	70
-5	110	850 (EN)	2	1.8	70

**Battery capacity 24V DPH**

5	70	600 (EN)	2	1.8	50
-5	75	750 (EN)	2	1.8	50

**Minimum cable cross sectional area**

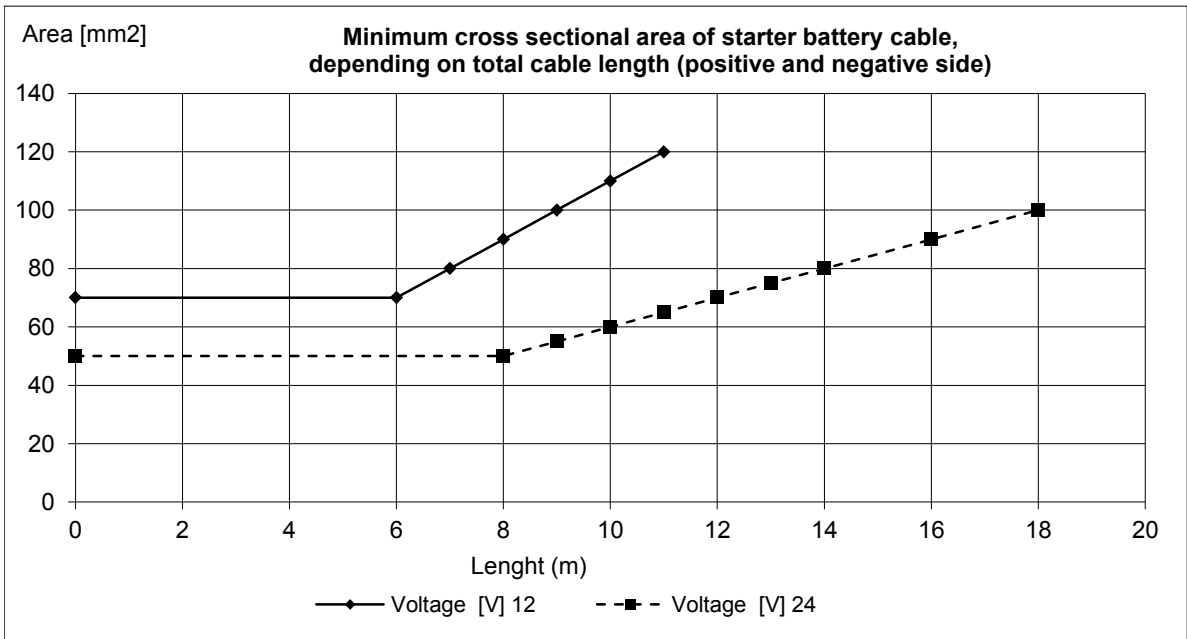

**Fuses size:**

	[A]
Engine:	10
Control system:	10

**Max current consumption during normal operation:**

	[A]
Engine :	2 - 4

**D6-340 AQ**

**Alternator data:**

Standard alternator charge curve (current vs. engine speed.)

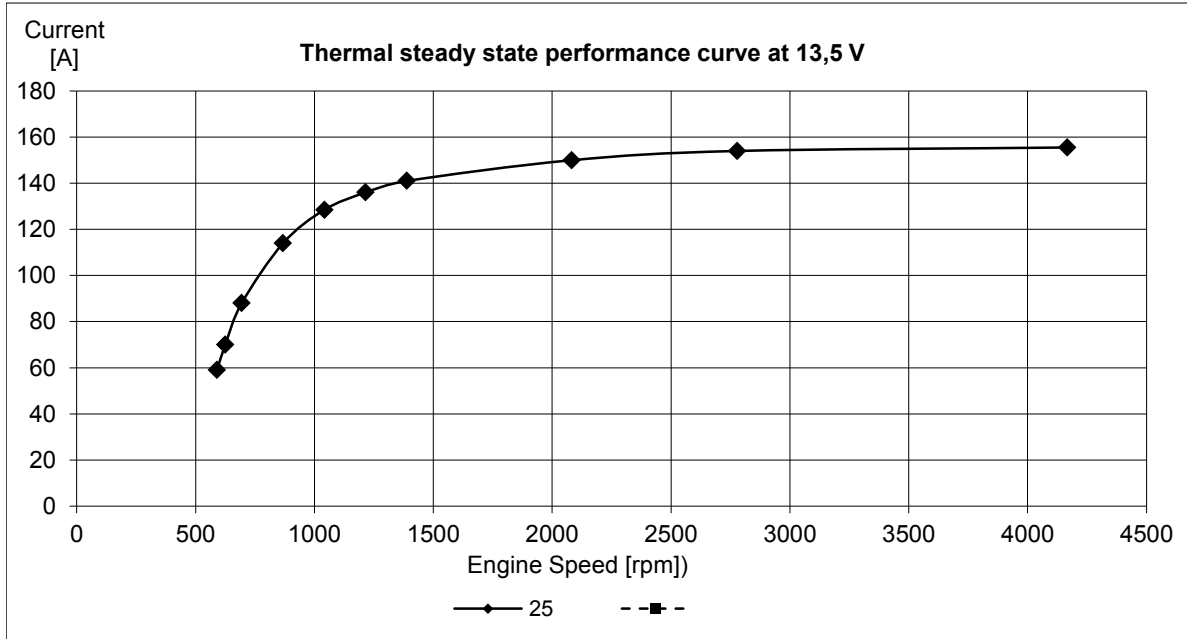

Constant charge voltage: [V]	14.3	+/- 0,3
------------------------------	------	---------

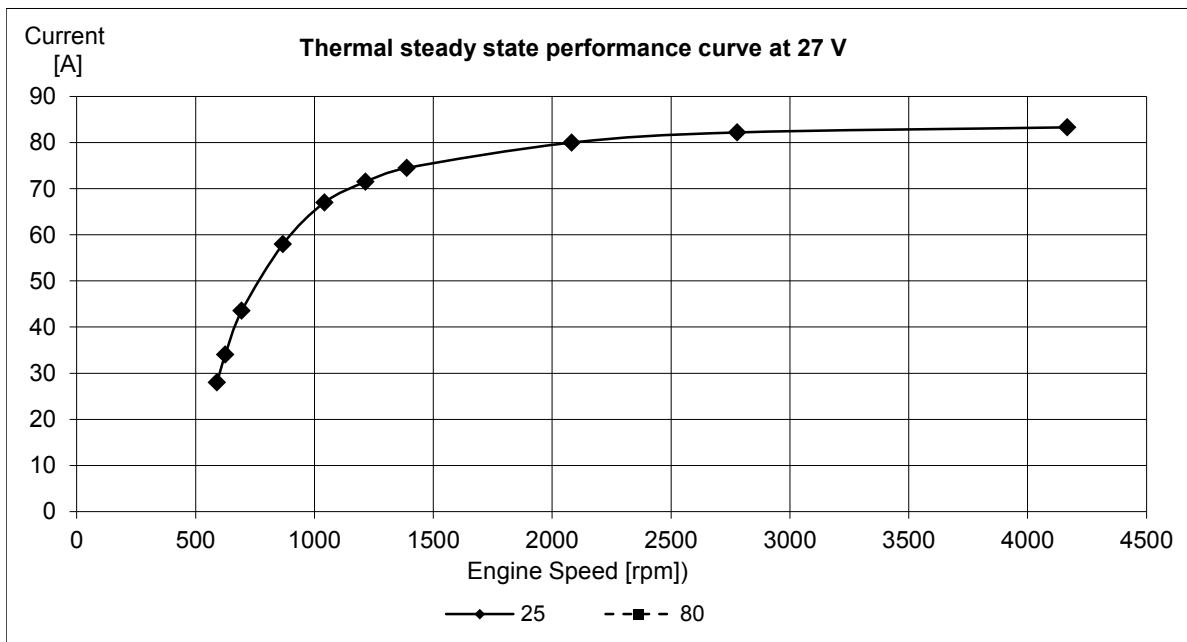

Constant charge voltage: [V]	28.3	+/- 0,3
------------------------------	------	---------

**Alternator data:**

Extra alternator charge curve (current vs. engine speed.)

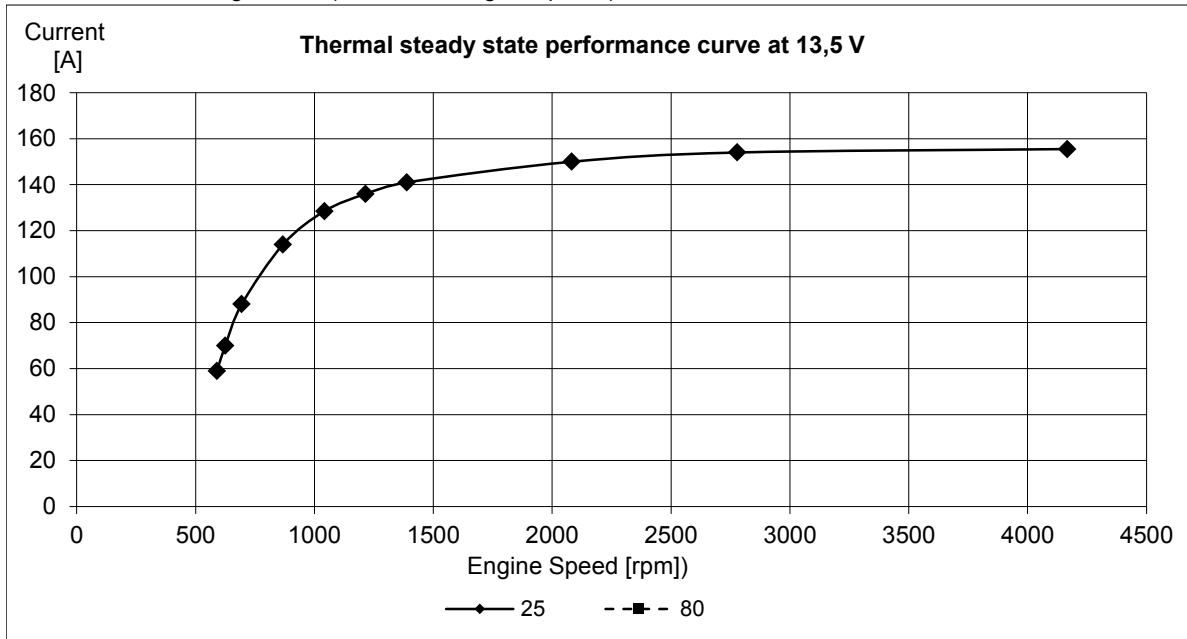

Constant charge voltage: [V]	14.3	+/- 0,3
------------------------------	------	---------

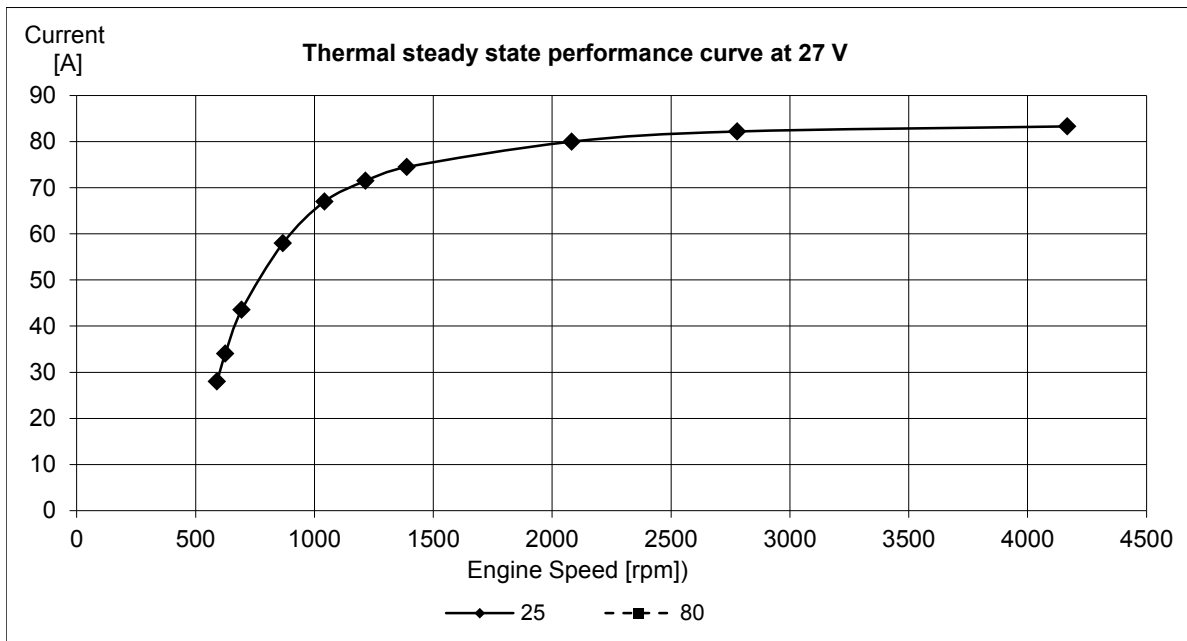

Constant charge voltage: [V]	28.3	+/- 0,3
------------------------------	------	---------