

<b>VOLVO PENTA</b>	Document No	Issue Index
	<b>23609292</b>	<b>03</b>

**D4-320 AQ****General**

4-stroke direct injected, turbocharged and aftercooled diesel engine

Engine Rating		5
Number of cylinders		4
No of valves		16
Displacement, total	litres	3.67
	in <sup>3</sup>	223.7
Firing order		1-3-4-2
Rotational direction, viewed from the front		Clockwise
Bore	mm	103
	in	4.06
Stroke	mm	110
	in	4.33
Compression ratio		18.0:1
Compression pressure at 240 rpm	MPa psi	
Max. static forward inclination:	°	5
Max. static backward inclination:	°	10
Max. intermittent forward inclination while running:	°	10
Max. intermittent backward inclination while running:	°	20
Max. intermittent side inclination while running:	°	22.5 or 30 for max 30 sec
Idling speed	rpm	700-750
Rated speed R5	rpm	3600
Governed speed R5	rpm	3730
Propeller selection range R5		3550-3730
Dry weight engine BT	kg	525
	lb	1157
Dry weight with drive DPI	kg	670
	lb	1477
Dry weight with drive DPH	kg	660
	lb	1455
	kg	
	lb	
	kg	
	lb	

- 1) ISO 3046, fuel temp 40°C.  
ISO 8665 (=SAE J 1228=ICOMIA 28-83)
- 2) At power according to 1).
- 4) Acc. to ISO 3744
- 5) At installed back pressure

<b>VOLVO PENTA</b>	Document No	Issue Index
	<b>23609292</b>	<b>03</b>

**D4-320 AQ**

<b>Performance</b>	<b>rpm</b>	<b>1000</b>	<b>1500</b>	<b>2000</b>	<b>2500</b>	<b>2800</b>	<b>3000</b>	<b>3200</b>	<b>3500</b>	<b>3600</b>	<b>3700</b>
Crankshaft power 1), 5)	kW	52	104	157	196	220	230	233	235	235	235
	hp	71	141	214	267	299	313	317	320	320	320
Propeller shaft power 1) (At full load)	kW	50	100	151	189	211	221	224	226	226	226
	hp	68	136	205	256	287	300	304	307	307	307
Propellershaft power at prop. load x <sup>2.5</sup>	kW	9	25	52	91	120	143	168	210	226	226
	hp	12	34	71	123	164	195	229	286	307	307
Propellershaft power at prop. load x <sup>3</sup>	kW	5	16	39	76	106	131	158	207	226	226
	hp	7	22	53	103	144	178	215	282	307	307
Torque at crankshaft 2)	Nm	500	662	750	750	750	732	695	641	623	607
	lbf ft	369	488	553	553	553	540	513	473	460	447
Mean piston speed	m/s	3.7	5.5	7.3	9.2	10.3	11.0	11.7	12.8	13.2	13.6
	ft/s	12.0	18.0	24.1	30.1	33.7	36.1	38.5	42.1	43.3	44.5
Effective mean pressure 2)	MPa	1.72	2.27	2.57	2.57	2.57	2.51	2.38	2.20	2.14	2.08
	psi	248.8	329.1	372.7	372.9	373.0	364.0	345.7	318.7	309.9	301.5
Max combustion pressure 2)	MPa	163	19.0	19.5	19.0	19.5	20.0	19.5	19	19	19
	psi	23641	2756	2828	2756	2828	2901	2828	2756	2756	2756

**Lubricating system**

Specific lubricating oil consumption.	g/kWh	< 0.2
Max. oil volume including filters for all allowed installation inclinations:	litres	12
	US gal	3.17
Max. oil volume excluding filters for all allowed installation inclinations:	litres	10.5
	US gal	2.77
Min. oil volume excluding filters for all allowed installation inclinations:	litres	9.3
	US gal	2.46

<b>Fuel system</b>	<b>rpm</b>	<b>1000</b>	<b>1500</b>	<b>2000</b>	<b>2500</b>	<b>2800</b>	<b>3000</b>	<b>3200</b>	<b>3500</b>	<b>3600</b>	<b>3700</b>
Specific fuel consumption 2)	g/kWh	235	232	226	208	202	208	211	218	223	224
	lb/hph	0.381	0.376	0.366	0.337	0.327	0.337	0.342	0.353	0.361	0.363
Fuel consumption, Test cycle E5 EU	g/kWh	223									
	lb/hph	0.36									
Fuel consumption at prop. load x <sup>2.5</sup>	l/h	2.8	7.0	13.7	23.8	31.5	36.2	44.0	57.4	62.7	63.0
	US gal/h	0.7	1.8	3.6	6.3	8.3	9.6	11.6	15.2	16.6	16.6

<b>Fuel system</b>	<b>rpm</b>	<b>1000</b>	<b>1500</b>	<b>2000</b>	<b>2500</b>	<b>2800</b>	<b>3000</b>	<b>3200</b>	<b>3500</b>	<b>3600</b>	<b>3700</b>
Fuel consumption at prop. load x <sup>3</sup>	l/h	2.1	4.9	10.6	20.4	28.2	34.8	42.7	56.6	62.7	63.0
	US gal/h	0.6	1.3	2.8	5.4	7.4	9.2	11.3	15.0	16.6	16.6
Fuel consumption at full load	l/h	14.7	28.9	42.5	48.9	53.2	57.3	58.8	61.3	62.7	63.0
	US gal/h	3.9	7.6	11.2	12.9	14.0	15.1	15.5	16.2	16.6	16.6

**Full load performance at rated speed**

Fuel inlet temperature	°C	40
	°F	104
Fuel return temperature from engine	°C	65
	°F	149
Fuel consumption	l/h	62.7
	US gal/h	16.56
Fuel inlet flow to engine	l/h	89.7
	US gal/h	23.70
Fuel return flow from engine	l/h	27
	US gal/h	7.13

1) ISO 3046, fuel temp 40°C.

ISO 8665 (=SAE J 1228=ICOMIA 28-83)

2) At power according to 1).

4) Acc. to ISO 3744

5) At installed back pressure

<b>VOLVO PENTA</b>	Document No	Issue Index
	<b>23609292</b>	<b>03</b>

**D4-320 AQ**

<b>Intake and exhaust system</b>	<b>rpm</b>	<b>1000</b>	<b>1500</b>	<b>2000</b>	<b>2500</b>	<b>2800</b>	<b>3000</b>	<b>3200</b>	<b>3500</b>	<b>3600</b>	<b>3700</b>
Specific exhaust heating effect in percent of crankshaft power	%	24	36	44	58	58	59	64	66	68	68
Exhaust temperature at the exhaust pipe connecting flange after the turbo charger.	°C	364	472	500	473	426	416	412	403	405	403
	°F	687	882	932	883	799	781	774	757	761	757
Permitted exhaust back pressure after turbocharger at rated speed. (Installed back pressure)	kPa							Max	30		
	psi								4.4		
	kPa							Min	15		
	psi								2.2		

<b>Intake and exhaust system</b>	<b>rpm</b>	<b>1000</b>	<b>1500</b>	<b>2000</b>	<b>2500</b>	<b>2800</b>	<b>3000</b>	<b>3200</b>	<b>3500</b>	<b>3600</b>	<b>3700</b>
Engine air consumption at 25°C / 77°F atmospheric pressure 100kPa	m³/min	3.5	6	8.4	11.1	14.2	15.5	16.8	18.2	18.6	18.9
	cu.ft./min	123.6	211.9	296.6	392	501.5	547.4	593.3	642.7	656.9	667.4
Charge air pressure Inlet manifold	kPa	117	149	170	183	221	230	237	238	240	237
	psi	17.0	21.6	24.7	26.5	32.1	33.4	34.4	34.5	34.8	34.4
Exhaust gas flow	m³/min	7.9	15.8	22.8	27.5	31.5	33.3	34.7	35.9	36.6	36.9
	cu.ft./min	279	558	805.2	971.2	1112	1176	1225	1268	1293	1303

<b>Cooling system</b>	<b>rpm</b>	<b>1000</b>	<b>1500</b>	<b>2000</b>	<b>2500</b>	<b>2800</b>	<b>3000</b>	<b>3200</b>	<b>3500</b>	<b>3600</b>	<b>3700</b>
Radiated heat of crankshaft power at full load.	kW	2.5	4.4	5.9	5.9	6.7	7.0	7.1	7.0	7.1	7.1
Heat rejection to charge air cooler of crankshaft power at full load.	kW	7.6	15.6	24.5	28.4	40.7	46.1	54.9	58.3	61.6	65.3
Coolant heat rejection to HE, incl. engine oil cooler and excl. charge air cooler, of crankshaft power at full load.	kW	46.4	85.9	121.3	121.7	130.7	128.4	133.7	142.1	145.3	138.2
Coolant flow with fully open thermostat and std cooling system	l/min	58	91	122	154	175	188	208	221	227	232
	cu.ft./min	2.0	3.2	4.3	5.4	6.2	6.6	7.3	7.8	8.0	8.2
Extra water pump flow through charge air cooler	l/min										
	cu.ft./min										
Max. pump pressure at extra pump pressure side (pressure set system)	kPa										
	psi										
Max. permissible temperature on coolant in engine outlet	°C	55									
	°F	131									
Coolant volume engine, including heat exchanger and charge air cooler	litres	13									
	US gal.	3.43									
Max. additional coolant for cabin heater etc. with std. Expansion tank	litres	5									
	US gal.	1.32									
Maximum coolant flow to cabin heater etc.	l/min	30									
	cu.ft./min	1.06									
Thermostat, start open at	°C	78									
	°F	172									
Thermostat, fully open at	°C	90									
	°F	194									

- 1) ISO 3046, fuel temp 40°C.  
ISO 8665 (=SAE J 1228=ICOMIA 28-83)
- 2) At power according to 1).
- 4) Acc. to ISO 3744
- 5) At installed back pressure

<b>VOLVO PENTA</b>	Document No	Issue Index
	<b>23609292</b>	<b>03</b>

**D4-320 AQ**

Raw water circuit	rpm	1000	1500	2000	2500	2800	3000	3200	3500	3600	3700
Nominal raw water design flow	l/min	50	72	92	108	116	121	126	134	137	139
	cu.ft./min	1.8	2.5	3.2	3.8	4.1	4.3	4.4	4.7	4.8	4.9
Nominal raw water pump pressure head at design flow.	kPa	21	42	69	95	111	122	139	151	156	153
	psi	3.0	6.1	10.0	13.8	16.1	17.7	20.2	21.9	22.6	22.2
Maximum raw water pump suction head	kPa	-30									
	psi	-4.4									
Maximum additional pressure drop excl. reverse gear oil cooler	kPa										
	psi										
Pressure drop over reverse gear oil cooler (optional equipment)	kPa										
	psi										
Maximum raw water temperature entering heat exchanger	°C	32									
	°F	90									

1 circuit keel cooling system	rpm	1000	1500	2000	2500	2800	3000	3200	3500	3600	3700
Design point for keel cooler, engine outlet temperature	°C										
	°F										
Maximum temperature to engine from external cooling system circuit	°C										
	°F										
Maximum temperature to engine inlet from external cooling system circuit	°C										
	°F										
Coolant flow through keel cooler at design point	l/min										
	cu.ft./min										
Maximum coolant flow through keel cooler	l/min										
	cu.ft./min										
Pressure drop in external circuit, including piping	kPa										
	psi										
Coolant volume engine	litres										
	US gal.										

1 1/2 circuit keel cooling system (Two circuit	rpm	1000	1500	2000	2500	2800	3000	3200	3500	3600	3700
Design point for keel cooler, engine outlet temperature	°C										
	°F										
Maximum temperature to charge air cooler from external cooling system circuit	°C										
	°F										
Coolant flow through keel cooler at design point	l/min										
	cu.ft./min										
Maximum coolant flow through keel cooler	l/min										
	cu.ft./min										
Pressure drop in external circuit, including piping	kPa										
	psi										
Coolant volume engine	litres										
	US gal.										

2 circuit keel cooling system, LT	rpm	1000	1500	2000	2500	2800	3000	3200	3500	3600	3700
Maximum temperature to charge air cooler from external LT-cooling system	°C										27
	°F										81
Coolant flow through keel cooler, LT-cooling system circuit	l/min										139
	cu.ft./min										4.9
Pressure drop in external LT-cooling system circuit, including piping	kPa	50									
	psi	7.3									
Coolant volume charge air cooler	litres										
	US gal.										

- 1) ISO 3046, fuel temp 40°C.  
ISO 8665 (=SAE J 1228=ICOMIA 28-83)
- 2) At power according to 1).
- 4) Acc. to ISO 3744
- 5) At installed back pressure

<b>VOLVO PENTA</b>	Document No	Issue Index
	<b>23609292</b>	<b>03</b>

**D4-320 AQ**

<b>2 circuit keel cooling system, HT</b>		<b>rpm</b>	<b>1000</b>	<b>1500</b>	<b>2000</b>	<b>2500</b>	<b>2800</b>	<b>3000</b>	<b>3200</b>	<b>3500</b>	<b>3600</b>	<b>3700</b>
Design point for keel cooler, engine outlet temperature	°C											83
	°F											181
Maximum temperature to engine from external HT-cooling system circuit	°C											60
	°F											140
Coolant flow through keel cooler, HT-cooling system circuit at design point	l/min											100
	cu.ft./min											3.5
Maximum coolant flow through keel cooler, HT-cooling system circuit	l/min											232
	cu.ft./min											8.2
Pressure drop in external HT-cooling system circuit, including piping	kPa	70										
	psi	10.2										
Coolant volume engine	litres	13										
	US gal.	3.43										

<b>Emissions</b>		<b>rpm</b>	<b>1000</b>	<b>1500</b>	<b>2000</b>	<b>2500</b>	<b>2800</b>	<b>3000</b>	<b>3200</b>	<b>3500</b>	<b>3600</b>	<b>3700</b>
Smoke at prop. load x <sup>2.5</sup>	*BSU	0.1	0.1	0.2	0.3	0.2	0.2	0.2	0.2	0.6	0.6	0.6
Smoke at prop. load x <sup>3</sup>	*BSU	0.1	0.1	0.1	0.3	0.2	0.2	0.2	0.2	0.6	0.6	0.6
Noise at prop. load x <sup>2.5</sup> . 4)	dBA	98.3	101.7	104.4	106.8	108.4	109.3	110.2	110.2	111.6	112.0	112.5
Noise at prop. load x <sup>3</sup> . 4)	dBA	97.7	101.6	103.6	105.8	108.0	109.1	110.3	110.3	111.9	112.0	112.5

\*NB.! BSU are calculated values. Measured values are acc. to ISO 10054 in FSN units

- 1) ISO 3046, fuel temp 40°C.  
ISO 8665 (=SAE J 1228=ICOMIA 28-83)
- 2) At power according to 1).
- 4) Acc. to ISO 3744
- 5) At installed back pressure

Document No	Issue Index
<b>23609292</b>	<b>03</b>

Sensors : Control and Monitoring System							
Sensors	Signal	Range	Unit	Warning Initial Delay / Warning Delay	Warning Level	Derating Level	Engine protection action
Coolant level switch	Digital	ON/OFF		30 sec from start / 5 sec	Low (ON / Closed)	NA	Warning only
Coolant temperature	50-0 kΩ	-40 - 140	°C	30 sec from start / 5 sec	96	99	See derating map
Fuel temperature	50-0 kΩ	-40 - 140	°C		60	NA	Warning only
Engine speed cam	Frequency		rpm	Instant	Lost signal	NA	Warning only
Engine speed crank	Frequency		rpm	Instant	Lost signal	NA	Warning only
Oil level sensor	Digital	ON/OFF		30 sec from start / 5 sec	Low level	NA	Warning only
Oil temperature	PT1000	-40 - 150	°C	30 sec from start / 5 sec	132	135	See derating map
Water In fuel switch	Digital	ON/OFF		All the time	Water in fuel	NA	Warning only
Wet Exhaust temp	PT200	0 - 850	°C	30 sec from start / 5 sec	90	95	See derating map

Sensors (rpm dependent)	Signal	Range	Unit	Initial Delay / Delay	Warning Level / Derating Level / Shutdown Level rpm Map					Comment
					0 rpm	1200 rpm	2000 rpm	2500 rpm	3600 rpm	
<b>Charge air temperature</b>	50-0 kΩ	-40 - 130	°C		<b>0 rpm</b>	<b>1200 rpm</b>	<b>2000 rpm</b>	<b>2500 rpm</b>	<b>3600 rpm</b>	
Warning Level			°C	30 sec from start / 5 sec	100	100	70	70	70	
Derating Level			°C							See derating map
<b>Fuel pressure</b>	0,5-4,5 V	0-200	kPa		<b>0 rpm</b>	<b>600 rpm</b>	<b>1600 rpm</b>	<b>2600 rpm</b>	<b>3600 rpm</b>	
Warning Level			kPa	30 sec from start / 5 sec	50	50	50	50	50	
Derating Level			kPa	NA	NA	NA	NA	NA	NA	
<b>Oil pressure</b>	0,5-4,5 V	0-700	kPa		<b>0 rpm</b>	<b>600 rpm</b>	<b>1200 rpm</b>	<b>2000 rpm</b>	<b>3600 rpm</b>	
Warning Level			kPa	30 sec from start / 5 sec	-50	75	150	200	230	
Derating Level (30% remain trq.)			kPa	10% trq. decr. per sec	-50	70	120	170	200	

Warning = Yellow Lamp active

Derating = Red Lamp active

## Derating map

<b>Charge Air Temp [°C]</b>	<b>rpm</b>	<b>75°C</b>	<b>80°C</b>	<b>85°C</b>
Remaining torque in %	600	100%	100%	100%
	1600	100%	100%	100%
	2200	100%	75%	50%

<b>Coolant temp [°C]</b>	<b>rpm</b>	<b>99°C</b>	<b>104°C</b>	<b>108°C</b>
Remaining torque in %	600	100%	100%	100%
	1600	100%	85%	75%
	2200	100%	75%	50%

<b>Oil temp [°C]</b>	<b>rpm</b>	<b>135°C</b>	<b>137.5°C</b>	<b>140°C</b>
Remaining torque in %	600	100%	100%	100%
	1600	100%	85%	75%
	2200	100%	75%	50%

<b>Oil pressure [kPa]</b>	<b>rpm</b>	
Remaining torque in %	600	85%
	1600	70%
	2200	50%

<b>Wet exhaust temp [°C]</b>	<b>rpm</b>	<b>95°C</b>	<b>105°C</b>	<b>115°C</b>	<b>125°C</b>
Remaining torque in %	600	100%	100%	100%	100%
	1600	100%	85%	80%	75%
	2200	100%	75%	65%	50%

**VOLVO PENTA**

Document No

**23609292**

Issue Index

**03**

Transmission: Control and Monitoring System: DPI Drive							Engine protection action
Sensors	Signal	Range	Unit	Warning Initial Delay / Warning Delay	Warning Level	Derating Level	
Gear oil temperature (EVC)	50-0 k $\Omega$	-30 - 130 $\pm$ 4%	$^{\circ}$ C	N/A	95		Warning only
Gear oil pressure (EVC)	Frequency	0-3000 $\pm$ 3%	kPa	60 sec from start / 7 sec	700		Warning only

Transmission: Control and Monitoring System: Reverse Gear							Engine protection action
Sensors	Signal	Range	Unit	Warning Initial Delay / Warning Delay	Warning Level	Derating Level	
Gear oil temperature (EVC)	50-0 k $\Omega$	-30 - 130 $\pm$ 4%	$^{\circ}$ C	N/A	95		Warning only

Transmission: Control and Monitoring System: IPS Drive							Engine protection action
Sensors	Signal	Range	Unit	Warning Initial Delay / Warning Delay	Warning Level	Derating Level	
Gear oil temperature (EVC)	50-0 k $\Omega$	-30 - 130 $\pm$ 4%	$^{\circ}$ C	N/A	95		Warning only
Gear oil pressure (EVC)	Frequency	0-3000 $\pm$ 3%	kPa	60 sec from start / 7 sec	700		Warning only

<b>VOLVO PENTA</b>	Document No	Issue Index
	<b>23609292</b>	<b>03</b>

D4-320 AQ

**Technical data - Drive unit**

Drive line		DPI with D4/D6
Transmission type		DPI-A
Gear ratio (total)		1,69:1 and 1,85:1
Steering angle, max.		+/- 24°
Total weight of drive unit (1)	kg	154
Oil capacity, approx.	litres	5.7
Oil volume difference MIN-MAX	litres	0.3
Oil type drive		Volvo Penta API GL5 75W/90
Propeller range		H2-H10

(1) Drive, Transom shield kit, including oil and various installation components. Propellers are not included in total weight

**"Generalized maximum load document"for DPI**

Valid products	Drive Unit	Gear Ratio
DPI-A with D6	DPI	1,69:1
DPI-A with D4	DPI	1,85:1

Loads provided in chart are single maximum loads i.e. not to be used for fatigue calculations

Speed range (top speed)	Load vektor	Maximum load
25-50 kn	Fx	18 kN
	Fy (+/-)	11 kN
	MCL rudder (+/-)	1.6 kNm

Fy load coordinate	570 mm
Fy load coordinate	330 mm

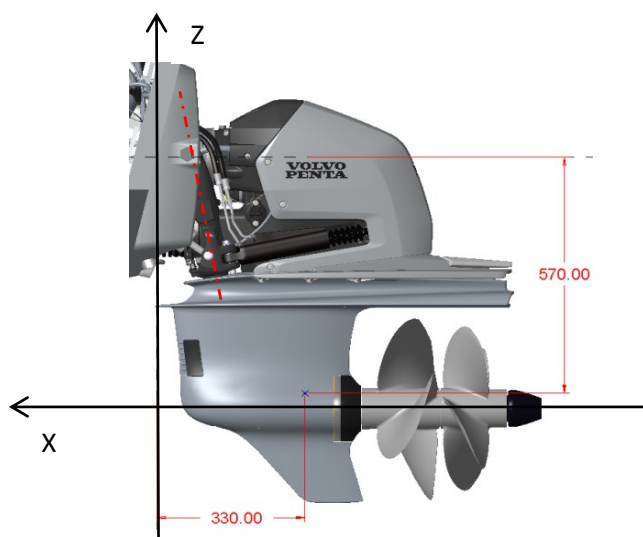

**VOLVO PENTA**

Document No

Issue Index

**D4-320 AQ**

**23609292**

**03**

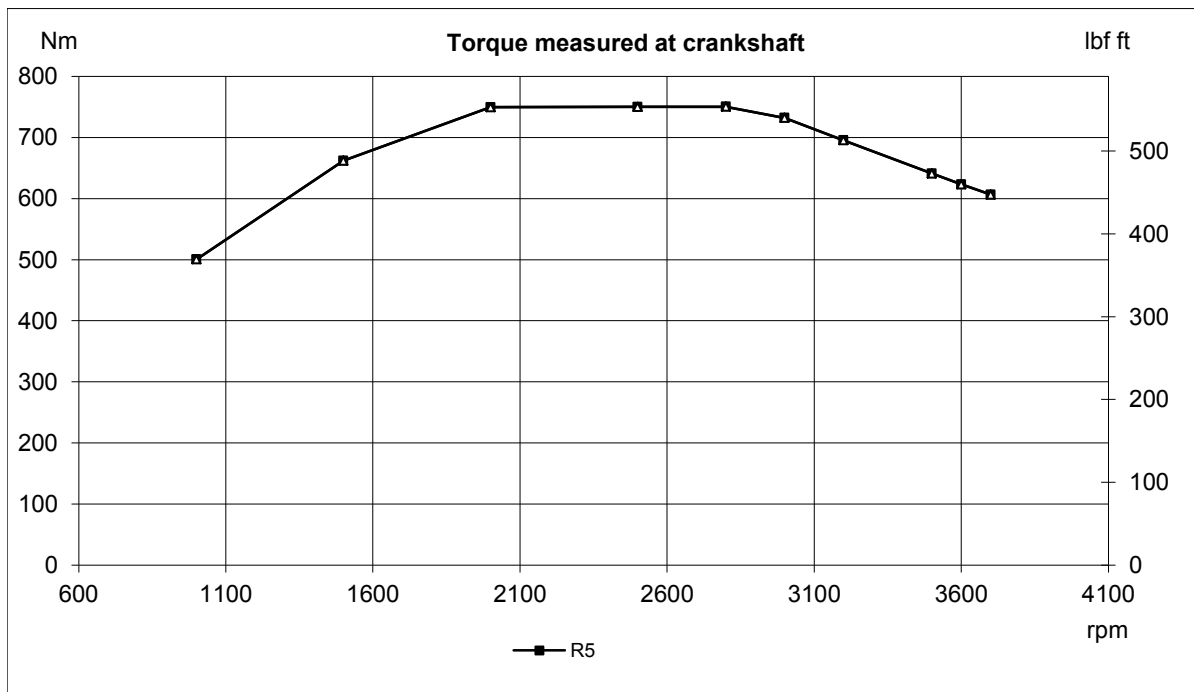
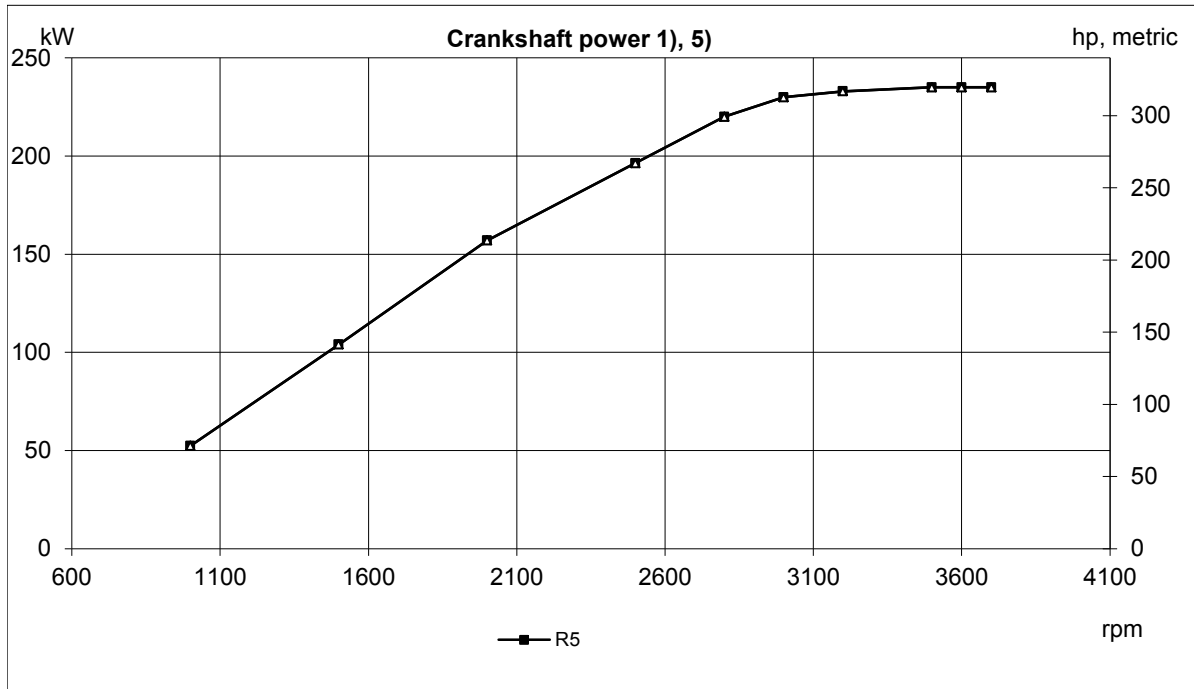

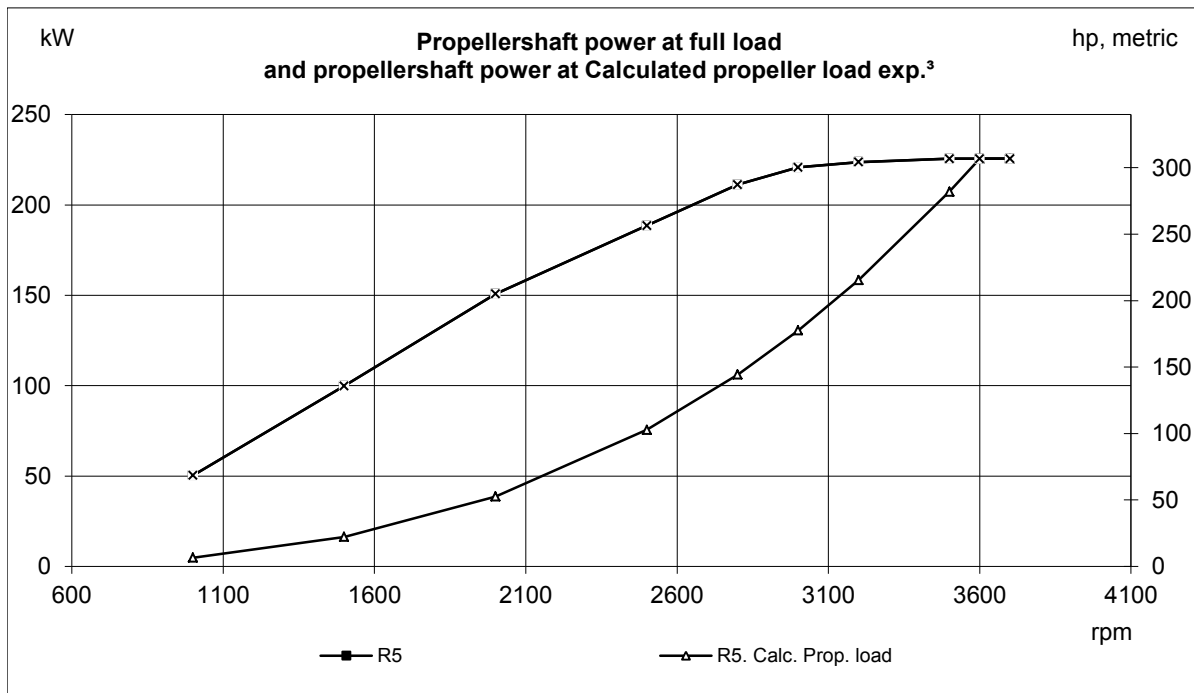
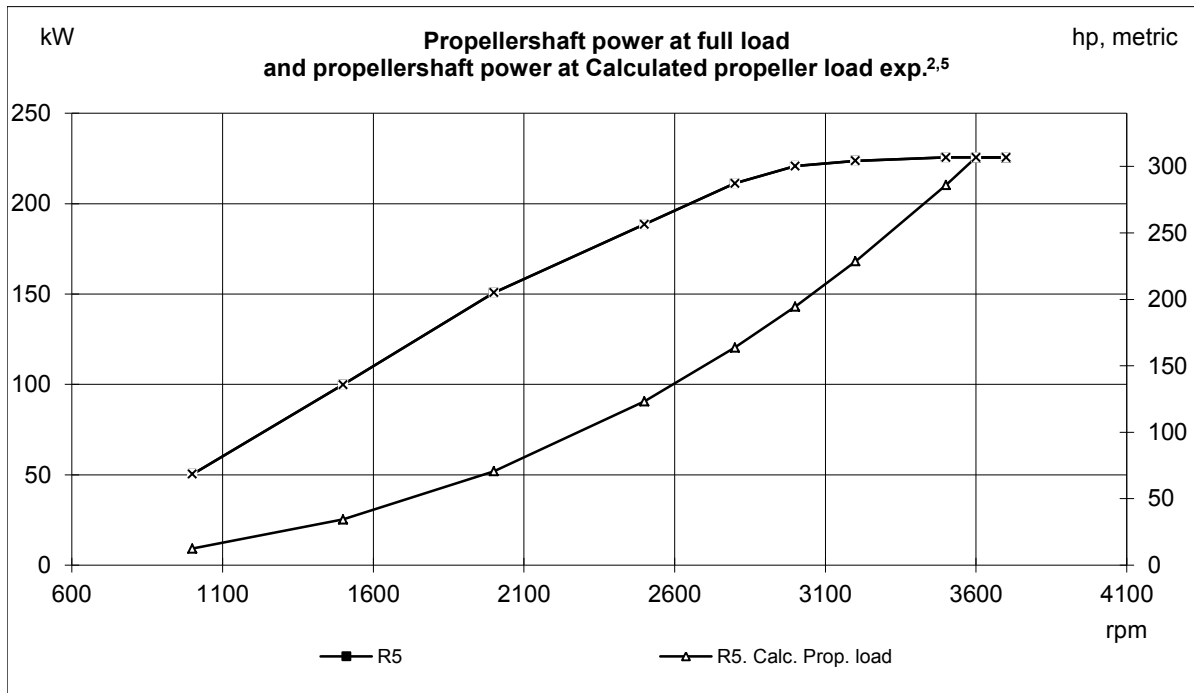

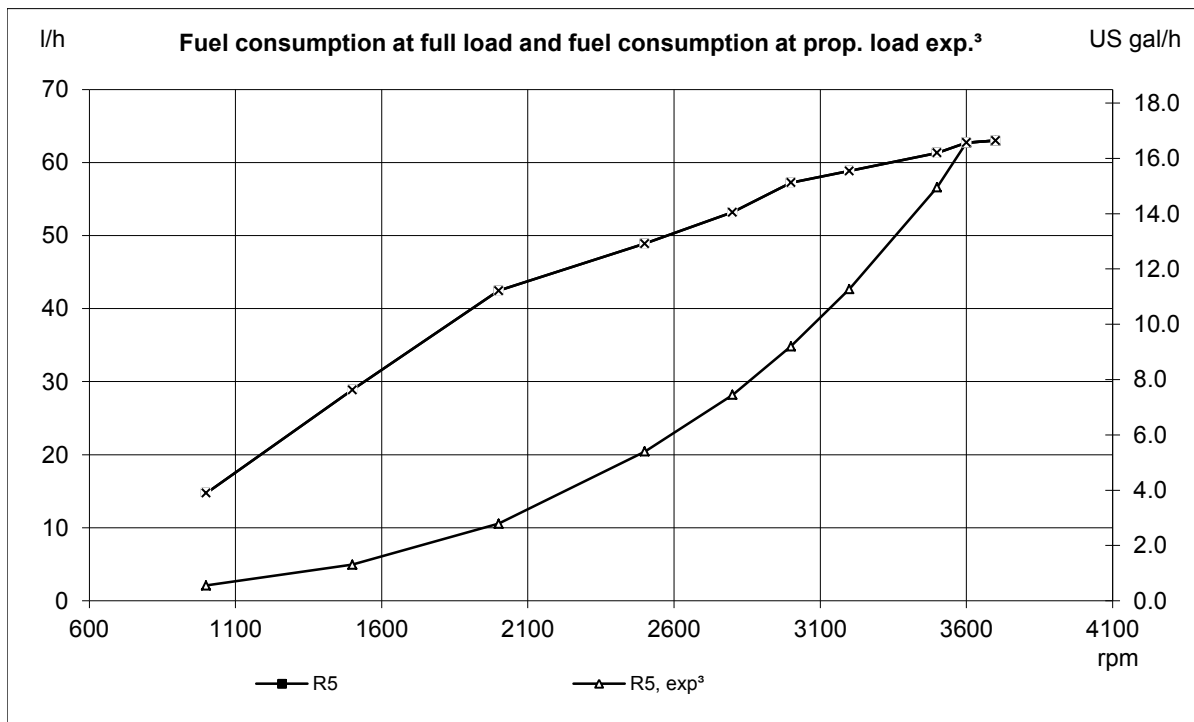
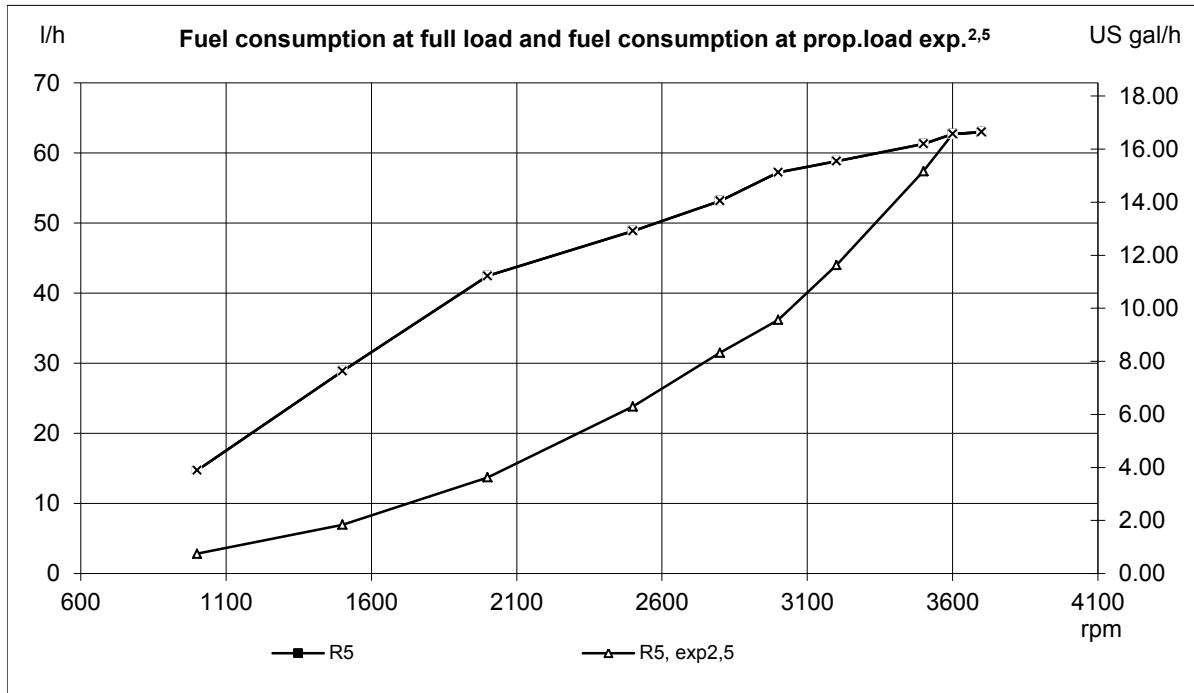

**VOLVO PENTA**

Document No

**23609292**

Issue Index

**03**

**D4-320 AQ**

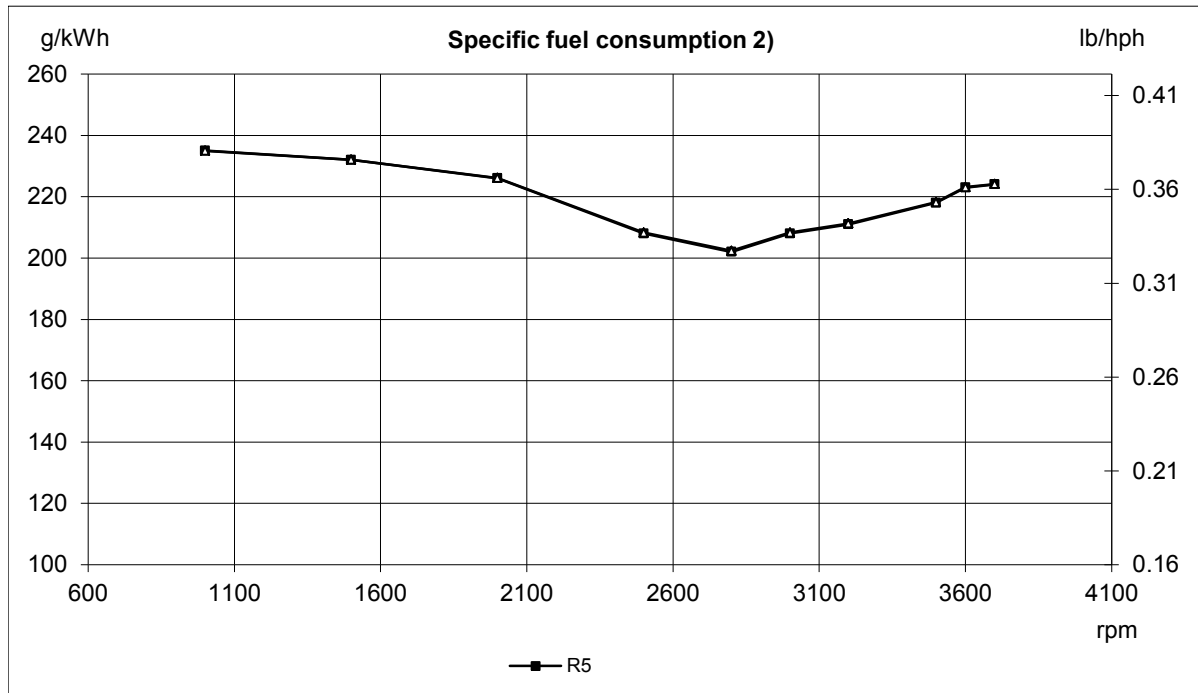

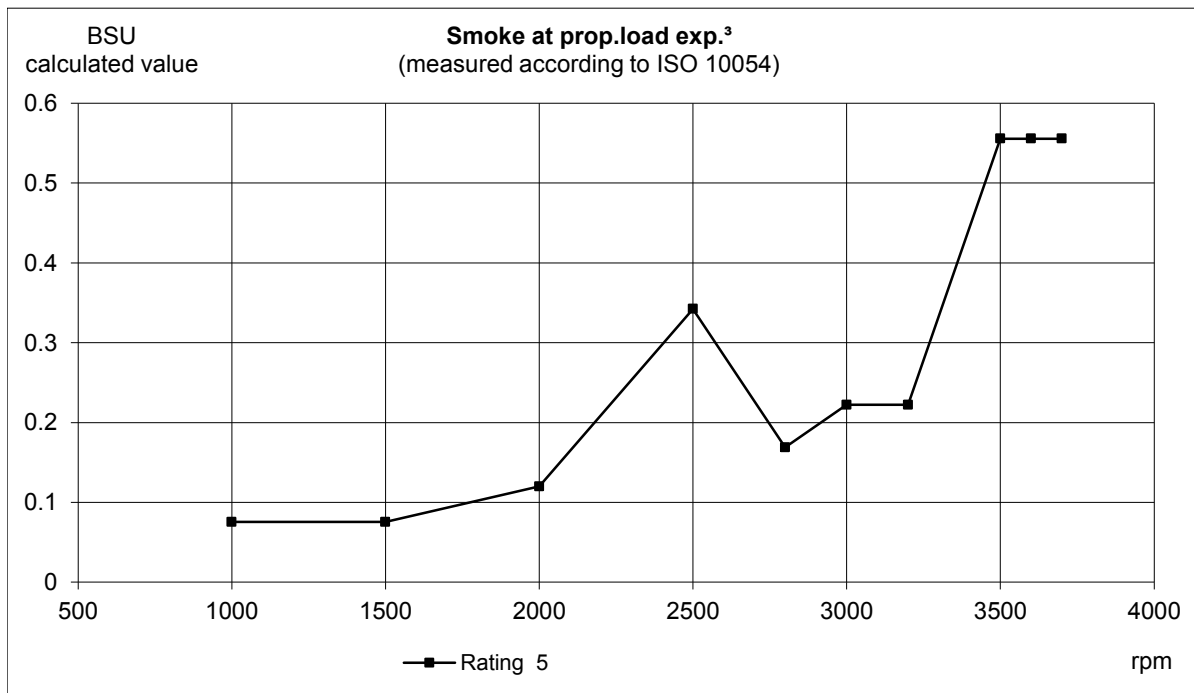
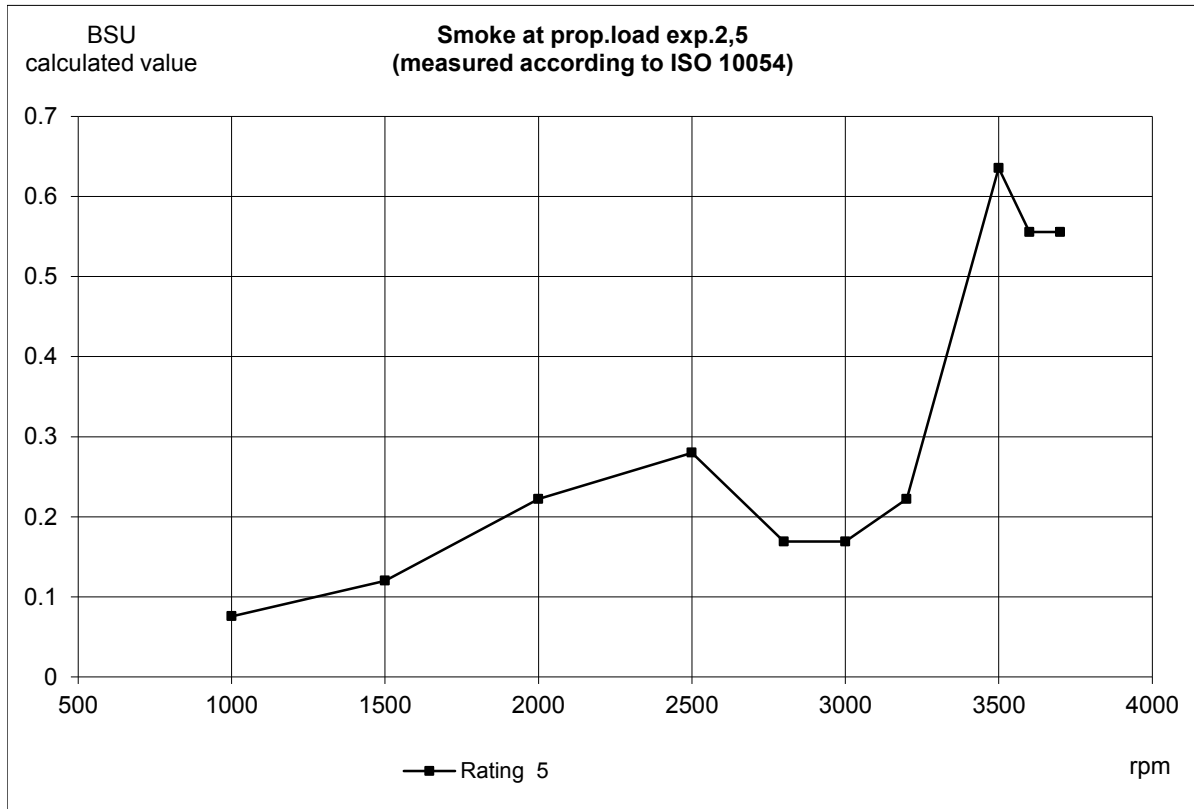

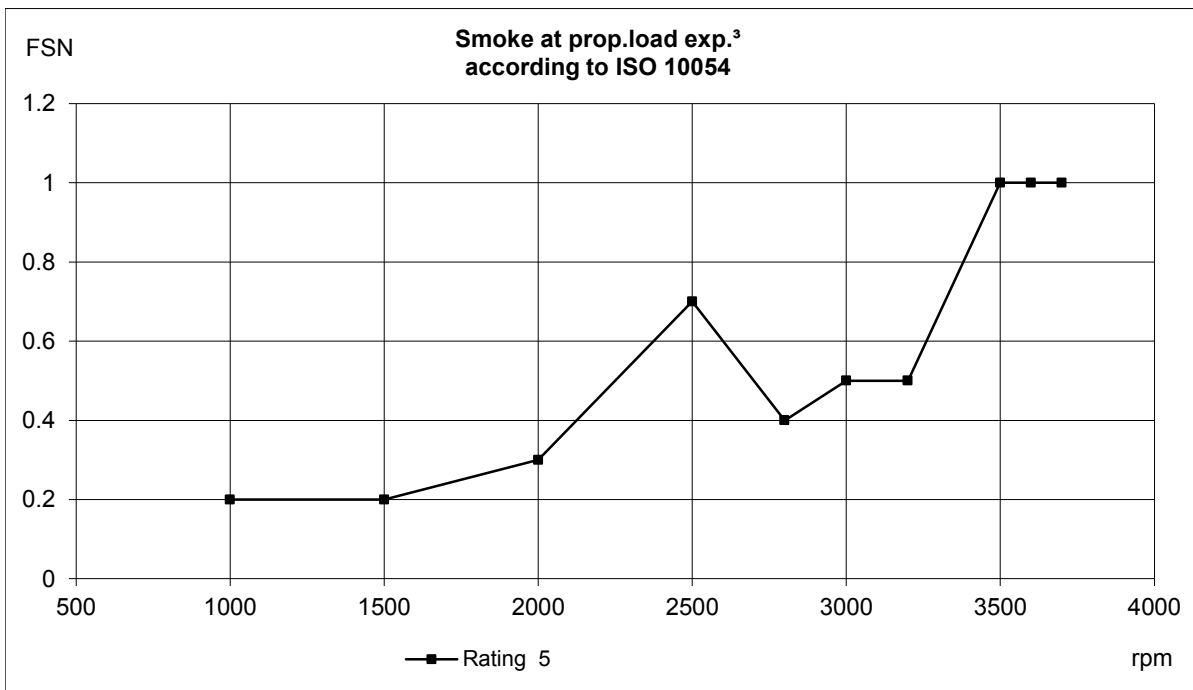
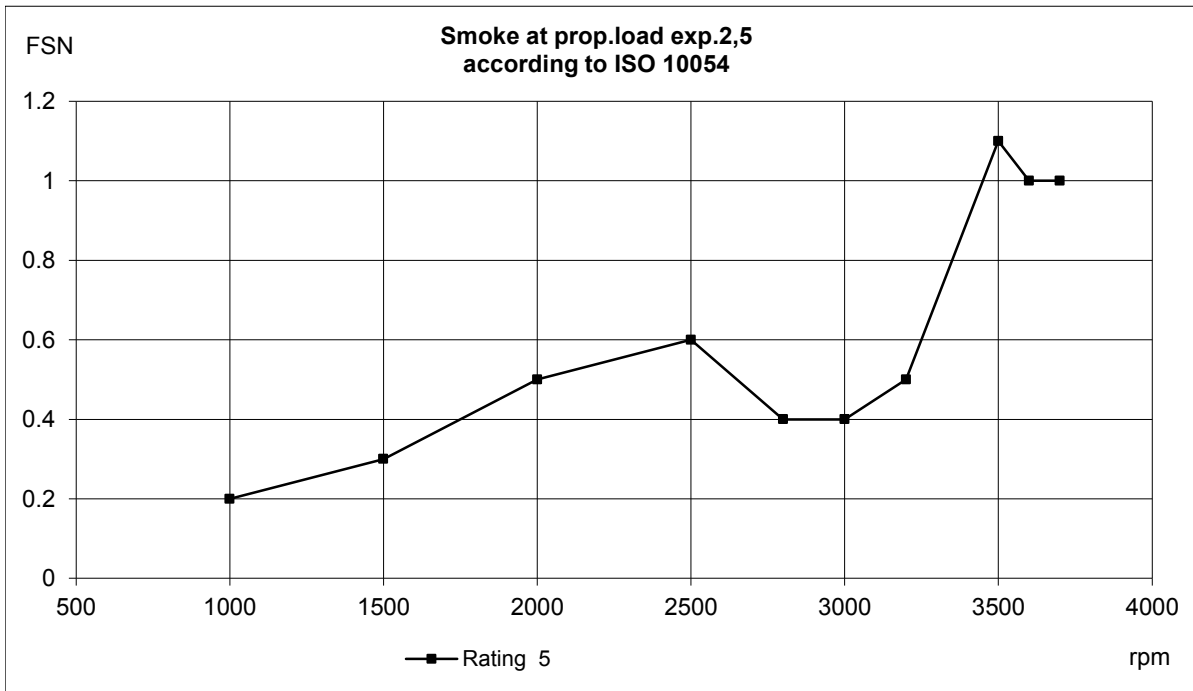

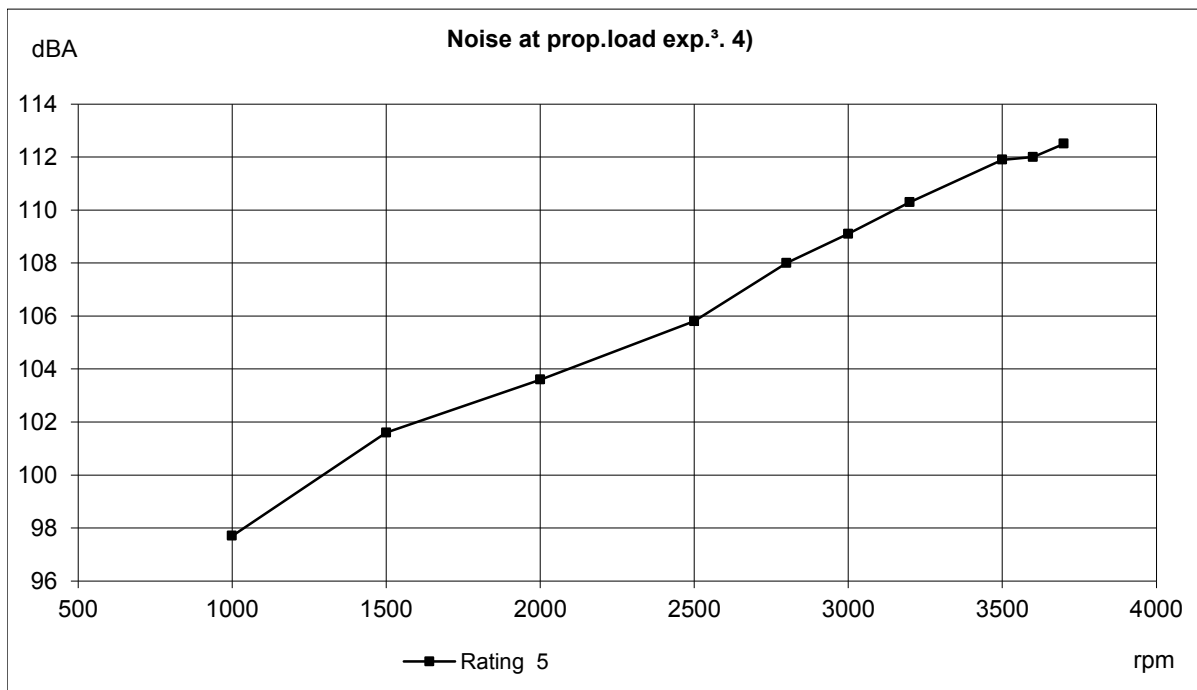
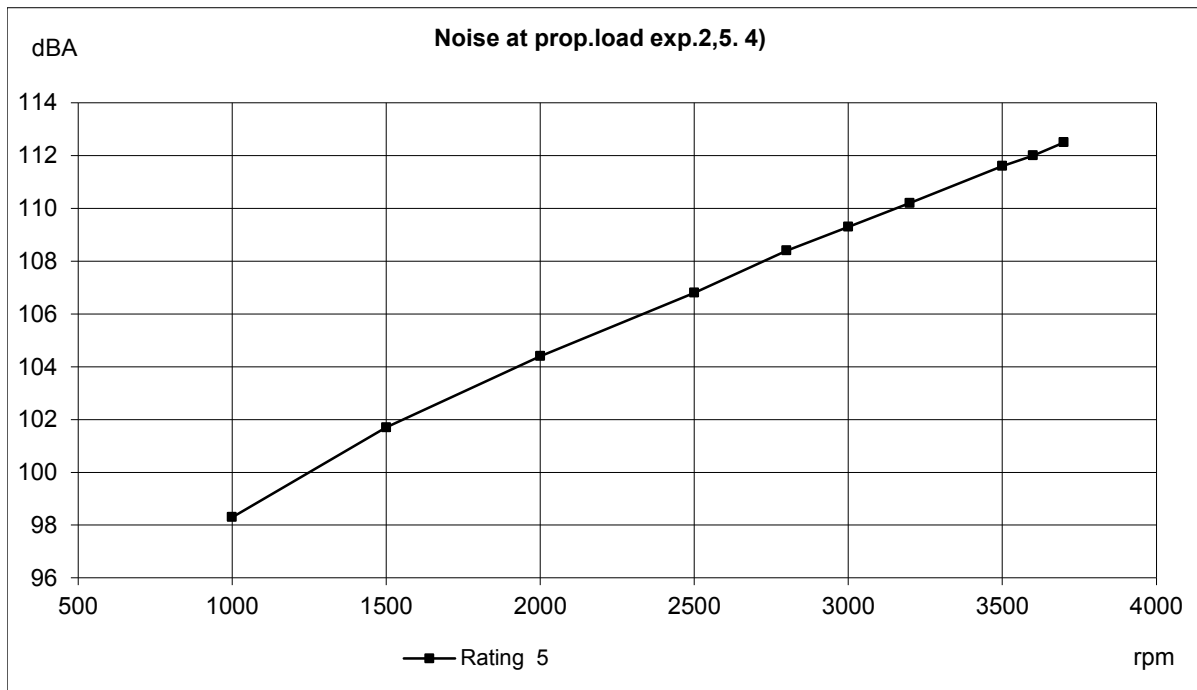

<b>VOLVO PENTA</b>	Document No	Issue Index
	<b>23609292</b>	<b>03</b>

**D4-320 AQ**

**Battery capacity 12V DPI**

Temp	Min battery size	CCA EN (Cold cranking Amps)	Max line resistance @ 20°C	Recommended max cable resistance @ 20°C	Min cross sectional area (due to heat increase)
[°C]	[Ah]	[A]	[mΩ]	[mΩ]	[mm <sup>2</sup> ]
5	95	850 (EN)	2	1.8	70
-5	120	1150 (EN)	2	1.8	70

**Battery capacity 24V DPI**

5	75	750(EN)	2	1.8	50
-5	95	850 (EN)	2	1.8	50

**Minimum cable cross sectional area**

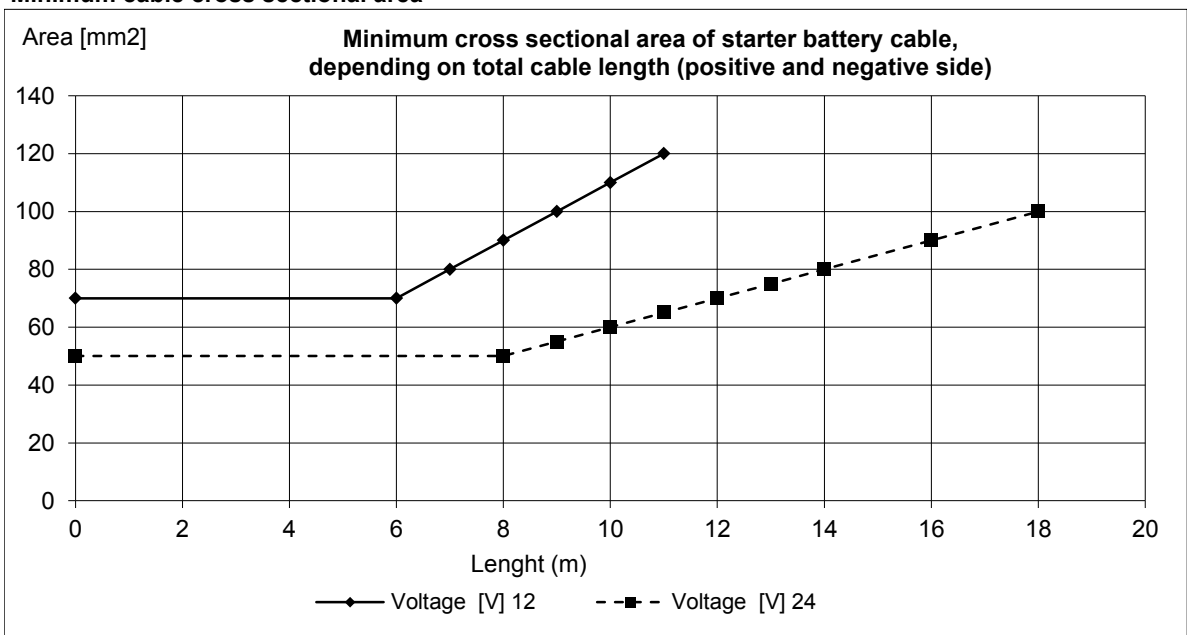

**Fuses size:**

	[A]
Engine:	10
Control system:	10

**Max current consumption during normal operation:**

	[A]
Engine :	2 - 4

**Alternator data:**

Standard alternator charge curve (current vs. engine speed.)

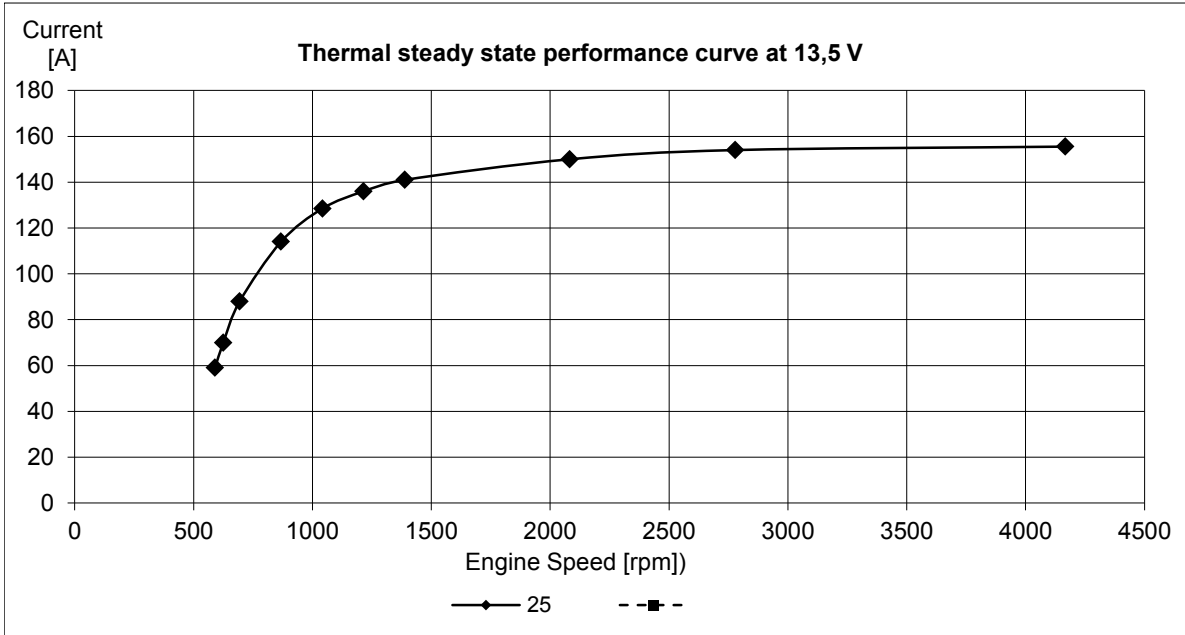

Constant charge voltage: [V]	14.3	+/- 0,3
------------------------------	------	---------

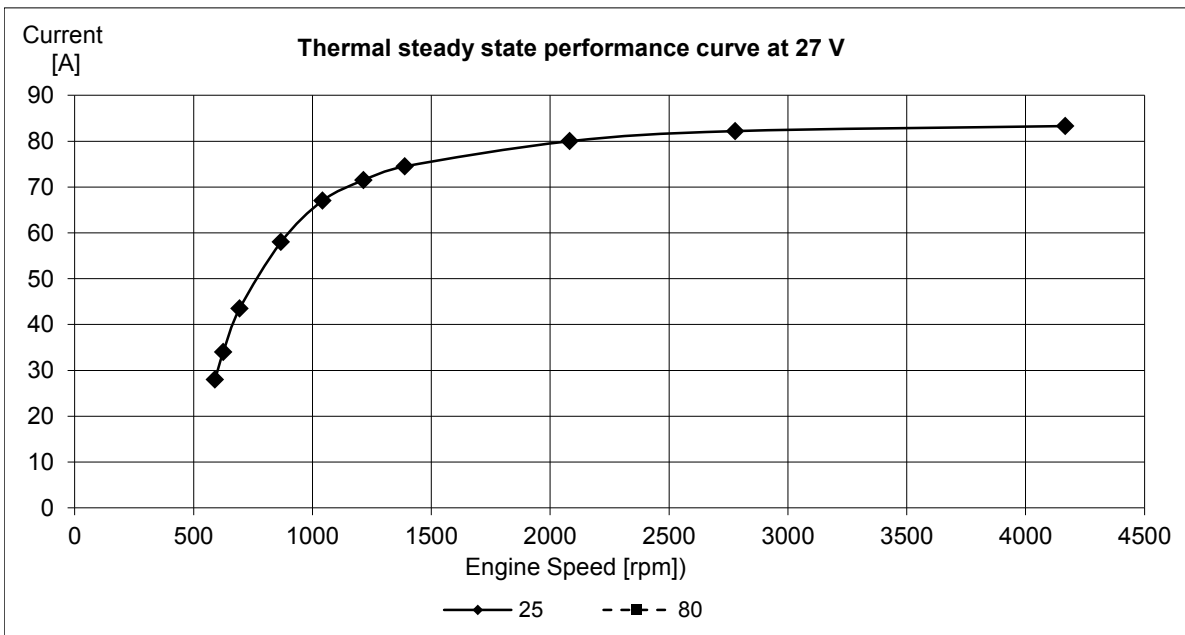

Constant charge voltage: [V]	28.3	+/- 0,3
------------------------------	------	---------

**Alternator data:**

Extra alternator charge curve (current vs. engine speed.)

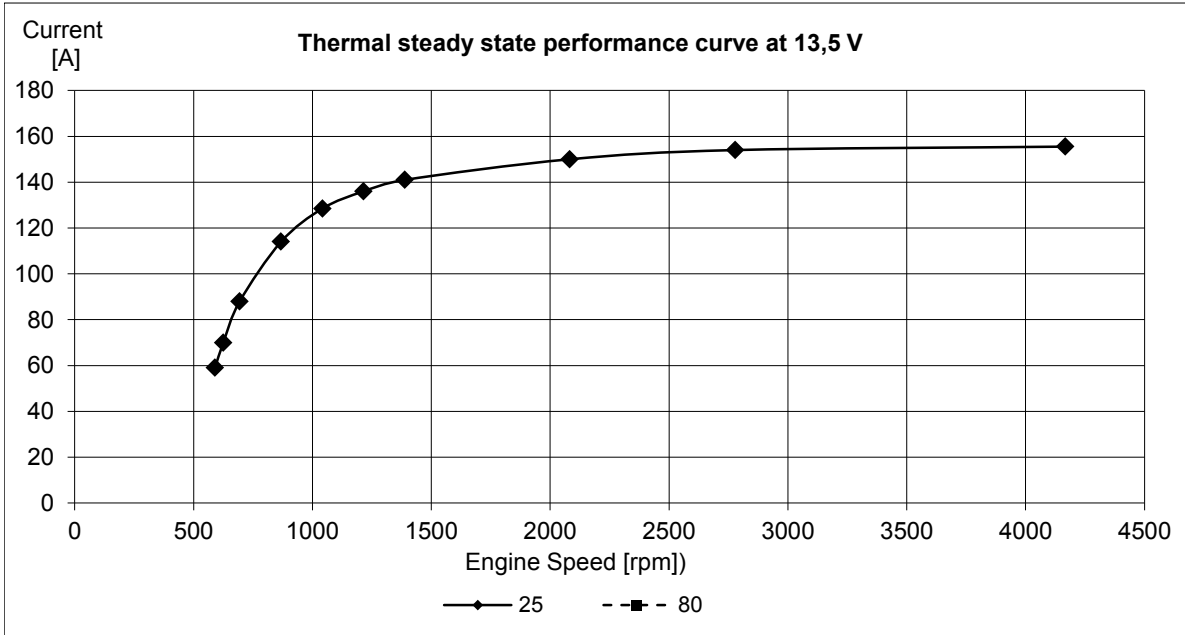

Constant charge voltage: [V]	14.3	+/- 0,3
------------------------------	------	---------

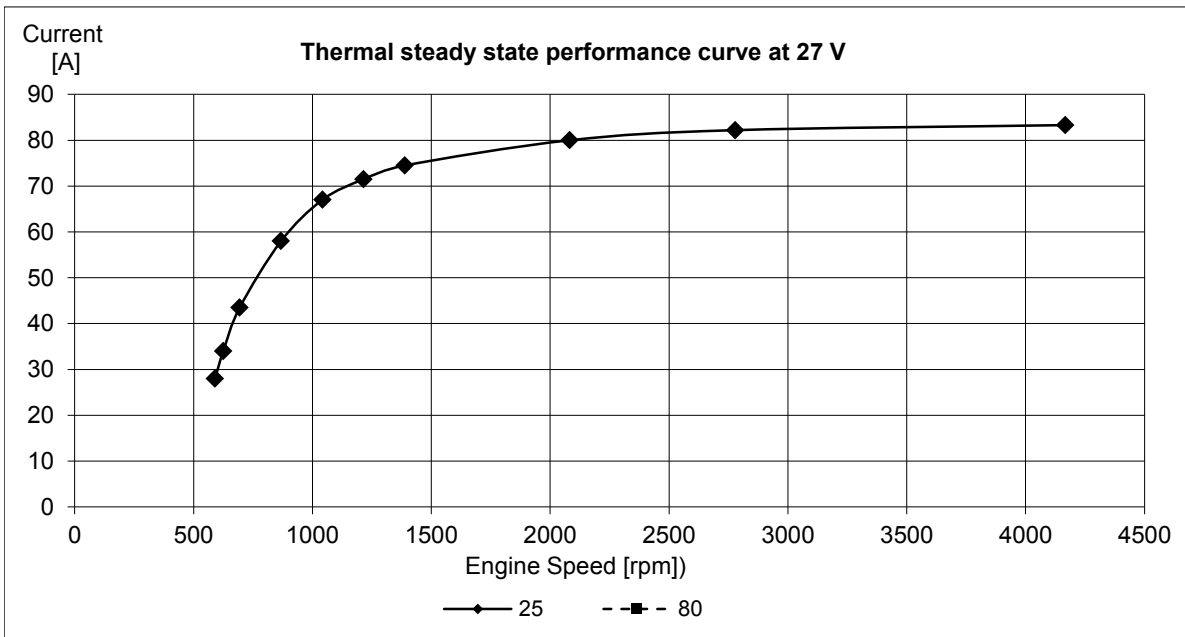

Constant charge voltage: [V]	28.3	+/- 0,3
------------------------------	------	---------