



mitsubishi S6U2-MPTK

Click on the headlines below to get redirected to the respective sections in this document.

[Technical data](#)
[Measure of overhaul](#)
[Flywheel & housing drawings](#)
[Starting air system](#)
[Cooling system](#)
[Performance curves](#)



**MITSUBISHI DIESEL ENGINE
TECHNICAL INFORMATION**

IFM NO.

JN04411-026(1/8)

DATE

July. 28, 2004

TITLE

Specification Sheets of S6U2-MPTK Engine (IMO Certified Engine)

Specification Sheets of S6U2-MPTK Engine that is satisfied with IMO certified engine are enclosed herein.

These specifications are subject to change without notification.

No.

DATE

SIGNATURE

CAUSE

S6U2-MPTK SPECIFICATION SHEET

MITSUBISHI DIESEL ENGINES

GENERAL ENGINE DATA

Type	4-Cycle, Water Cooled
Aspiration	Turbo-Charged, Inter Cooler (Fresh Water to Cooler)
Cylinder Arrangement	Inline
No. of Cylinders	6
Bore mm (in)	240 (9.45)
Stroke mm (in)	300 (11.81)
Displacement liter (in ³)	81.43 (4969)
Compression Ratio	13.4(12.4) : 1
Dry Weight - Engine only - kg (lb)	8650 (19069)
Wet Weight - Engine only - kg (lb)	9360 (20635)

PERFORMANCE DATA

Steady State Speed Stability Band at any Constant Load - %	±0.5
Idling Speed - rpm	370 - 420
Maximum Overspeed Capacity - rpm	1200
Moment of Inertia of Rotating Components GD ² - kgf · m ² (lbf · ft ²)	283.2 (6720)
(Includes Std. Flywheel)	
Cyclic Speed Variation with Flywheel at 1000 rpm	1/193
900 rpm	1/132

AIR INLET SYSTEM

Maximum Allowable Intake Air Restriction	
With Clean Filter Element - mm H ₂ O (in. H ₂ O)	300 (11.8)
With Dirty Filter Element - mm H ₂ O (in. H ₂ O)	760 (29.9)
Maximum Allowable Intake Air Temperature - °C (°F)	45 (113)

EXHAUST SYSTEM

Maximum Allowable Back Pressure - mm H ₂ O (in. H ₂ O)	450 (17.7)
--	------------

LUBRICATION SYSTEM

Oil Pressure at Idle - MPa (psi)	0.15 - 0.2 (21-28)
at Rate Speed - MPa (psi)	0.45 - 0.7 (64-100)
Standard Thermostat (modulating) Range - °C (°F)	55 - 75 (131-167)
Maximum Oil Temperature - °C (°F)	95 (203)
Oil Capacity of Standard Pan High - liter (U.S. gal.)	340 (89.8)
Low - liter (U.S. gal.)	230 (60.8)
Total System Capacity (Includes Oil Filter) - liter (U.S. gal.)	370 (97.8)
Maximum Installation Angle (Std. Pan) Front Up - °	10
(Includes Trim Angle) Front Down - °	10
Maximum Instantaneous Operating Angle Front Up - °	14
(Engine Level) Front Down - °	14
Side to Side - °	25

S6U2-MPTK SPECIFICATION SHEET **MITSUBISHI DIESEL ENGINES**

COOLING SYSTEM

MPTK (FW) Maximum Coolant (Fresh Water) Temperature at Air Cooler Inlet · °C (°F)	40(104)
Coolant Capacity (Engine only) · liter (U.S. gal.)	270 (71.3)
Maximum External Friction Head at Engine Outlet · MPa (psi)	0.1 (14.2)
Maximum Static Head of Coolant above Crankshaft Center · m (ft)	12.5 (41.0)
Maximum Outlet Pressure of Engine Water Pump · MPa (psi)	0.25 (35.6)
Standard Thermostat (modulating) Range · °C (°F)	65 -75 (149 - 167)
Maximum Allowable Coolant Temperature at Engine Outlet ·°C (°F)	95 (203)
Maximum Recommended Coolant Temperature at Engine Outlet ·°C (°F)	80 (176)
Maximum Allowable Pressure of Expansion Tank · MPa (psi)	0.07(10)
Minimum Coolant Expansion Space · % of System Capacity	10

FUEL SYSTEM

Fuel Injection Pump Type	Bosch Type × 6
Maximum Suction Head of Feed Pump · mmHg (in. Hg)	110 (4.3)
Maximum Static Head of Leak Pipe · mmHg (in. Hg)	370 (14.6)
Minimum Fuel Oil Supply Pipe Inner Diameter · mm(in)	25(1.0)
Minimum Fuel Oil Return Pipe Inner Diameter · mm(in)	25(1.0)
Minimum Fuel Oil Leak Pipe Inner Diameter · mm(in)	25(1.0)
Fuel Oil Tank Height from Inlet Port of Fuel Injection Pump · m (ft)	0 · 2 (0 - 6.56)

STARTING AIR SYSTEM

Air Reservoir Capacity · liter (U.S. gal)	200 (52.8)
No. of Air Reservoir	2
Air Pressure · MPa (psi)	2.94 (427)

STOP SYSTEM

Air Pressure · MPa (psi)	0.6 (85.4)
--------------------------	------------

S6U2-MPTK SPECIFICATION SHEET **MITSUBISHI DIESEL ENGINES**

ACCESSORY EQUIPMENT

Air Cleaner	Silencer Type
Exhaust Manifold.....	Lagging and Heat Insulated Plate
Turbocharger	Air Cooled (Turbine Case)
Inter cooler.....	Fresh Water Cooled
Breather	Conduction Type
Governor	Hydraulic UG8 or Electric EG10P Type
Fuel Injection Pump.....	Individual Unit Pump
Fuel Feed Pump	Trochoid Type
Fuel Injection Pipe	Double Walled Tube Type
Fuel Injection Nozzle	Whole Nozzle Type
Fuel Filter.....	Paper Element Type
Lubricating Oil Pump	Gear Pump
Lubricating Oil Cooler	Shell and Tube Type
Lubricating Oil Filter (Full Flow)	Paper Element Type
Lubricating Oil Filter (By Pass Flow)	Paper Element Type
Oil Pan	Large Capacity, Steel
Lubricating Oil Thermostat	Wax Pellet Type
Cooling Water Pump	Centrifugal Type
Cooling Water Thermostat	Wax Pellet Type
Air Starter	Air Direct Type
Stop device	Air Cylinder Type

ACCESSORY EQUIPMENT (LOOSE SUPPLY)

Jack Bolt
 Companion Flange
 Standard Tools
 Standard Spare Parts

The specifications are subject to change without notification.

S6U2-MPTK SPECIFICATION SHEET MITSUBISHI DIESEL ENGINES

ENGINE RATING

All data represent net performance with standard accessories such as fuel injection pump, water pump, L.O. pump under the following conditions:

Barometric pressure ; 100 kPa (750 mmHg)
 Ambient temperature ; 298 K (25 °C)
 Relative humidity ; 60%
 Calorific value of fuel ; 42,700kJ/kg

S:Limited Light Duty, A:Light Duty, B:Medium Duty, C:Heavy Duty

ITEM	UNIT	Propulsion use				Remarks
		S	A	B	C	
Engine Speed	rpm	1000	1000	960	930	
Brake Horse Power	kW	1380	1268	1156	1040	Fuel Set Power Flywheel End
	HP	1850	1700	1550	1394	
Specific Fuel Consumption	g/kWh	210	209	207	207	Allowance +5%
	g/HPH	157	156	154	154	
Break Mean Effective Press.	MPa	2.03	1.87	1.77	1.65	
	psi	289	266	252	234	
Mean Piston Speed	m/s	10.0	10.0	9.6	9.3	
	ft/min	1969	1969	1890	1831	
Maximum Regenerative Power Absorption Capacity	kW HP					
Intake Air Flow	m ³ /min	134	134	98	90	
	CFM	4728	4728	3460	3176	
Exhaust Gas Flow	m ³ /min	298	298	280	264	
	CFM	10513	10513	9887	9314	
Coolant (Jacket Water) Flow	l/min	1100	1100	1050	1030	
	US GPM	292	292	277	273	
Coolant(Jacket Water) Pressure (Water Pump Outlet)	MPa	0.13	0.13	0.13	0.12	
	psi	18	18	18	17	
Cooling water (A/C & O/C) Flow	l/min	1100	1100	1050	1030	FW temp<40°C
	US GPM	292	292	279	273	
Oil Flow	l/min	604	604	580	562	
	US GPM	160	160	154	149	
Radiated Heat to Ambient	×10 ⁴ kcal/h	8.88	8.10	7.32	6.60	
	BTU/min	5873	5357	4841	4365	
Heat Rejection to Coolant (Jacket Water)	×10 ⁴ kcal/h	26.58	24.30	21.96	19.74	
	BTU/min	17580	16072	14524	13056	
Heat Rejection to Air & Oil Cooler	×10 ⁴ kcal/h	39.90	36.48	32.94	29.64	
	BTU/min	26389	24128	21786	19604	

APPLICATION: MARINE-USE

ITEM	UNIT	Propulsion use				Remarks
		S	A	B	C	
Heat Rejection to Exhaust	×10 ⁴ kcal/h BTU/min	101.58 67184	92.34 61073	82.44 54525	74.16 49049	
Noise Level (Excludes exhaust gas)	dB(A)					Mechanical 1 m Dis. 1.5m H.
Max. No Load Governored Speed	rpm	1075	1075	1032	1000	

Note: Brake Horse Power at flywheel end.

The specifications are subject to change without notification.

APPLICATION: MARINE-USE

S6U2-MPTK SPECIFICATION SHEET MITSUBISHI DIESEL ENGINES

ENGINE RATING

All data represent net performance with standard accessories such as fuel injection pump, water pump, L.O. pump under the following conditions:

Barometric pressure ; 100 kPa (750 mmHg)
 Ambient temperature ; 298 K (25 °C)
 Relative humidity ; 60%
 Calorific value of fuel ; 42,700kJ/kg

ITEM	UNIT	Generator use				Remarks
		50 Hz	50Hz	60Hz	60Hz	
Engine Speed	rpm	1000	750	900	720	
Brake Horse Power	KW	1350	1015	1216	970	Fuel Set Power Flywheel End
	HP	1810	1360	1630	1300	
Specific Fuel Consumption	g/kWh	200	200	198	200	Allowance +5%
	g/HPH	149	149	148	149	
Break Mean Effective Press.	MPa	1.99	1.99	1.99	1.99	
	psi	289	289	289	289	
Mean Piston Speed	m/s	10.0	7.5	9.0	7.2	
	ft/min	1969	1476	1772	1417	
Maximum Regenerative Power Absorption Capacity	kW HP					
Intake Air Flow	m ³ /min	129	97	116	97	
	CFM	4552	3423	4093	3423	
Exhaust Gas Flow	m ³ /min	286	215	258	215	
	CFM	10091	7586	9103	7586	
Coolant (Jacket Water) Flow	l/min	1100	850	1000	850	
	US GPM	292	225	265	225	
Coolant(Jacket Water) Pressure (Water Pump Outlet)	MPa	0.13	0.08	0.11	0.08	
	psi	18	11	16	11	
Cooling water (A/C & O/C) Flow	l/min	1100	850	1000	850	FW temp<40°C
	US GPM	292	225	265	225	
Oil Flow	l/min	600	450	540	430	
	US GPM	159	119	143	114	
Radiated Heat to Ambient	×10 ⁴ kcal/h	8.26	6.21	7.37	5.94	
	BTU/min	5469	4112	4877	3930	
Heat Rejection to Coolant (Jacket Water)	×10 ⁴ kcal/h	24.79	18.64	21.96	19.74	
	BTU/min	16407	12336	14524	13056	
Heat Rejection to Air & Oil Cooler	×10 ⁴ kcal/h	37.18	27.95	33.15	26.71	
	BTU/min	24610	18504	21946	17683	

ITEM	UNIT	Generator use				Remarks
		50Hz	50Hz	60Hz	60Hz	
Heat Rejection to Exhaust	×10 ⁴ kcal/h	89.09	66.99	78.40	64.02	
	BTU/min	58976	44341	51899	42376	
Noise Level (Excludes exhaust gas)	dB(A)					Mechanical 1 m Dis. 1.5m H.
Max. No Load Governored Speed	rpm	1050	788	945	756	

Note: Brake Horse Power at flywheel end.

The specifications are subject to change without notification.

APPLICATION: MARINE-USE

SUエンジンオーバーホール時の所要寸法
 SU ENGINE OVERHAUL HEIGHT AND LENGTH

(S6U, S6U2, S8U)

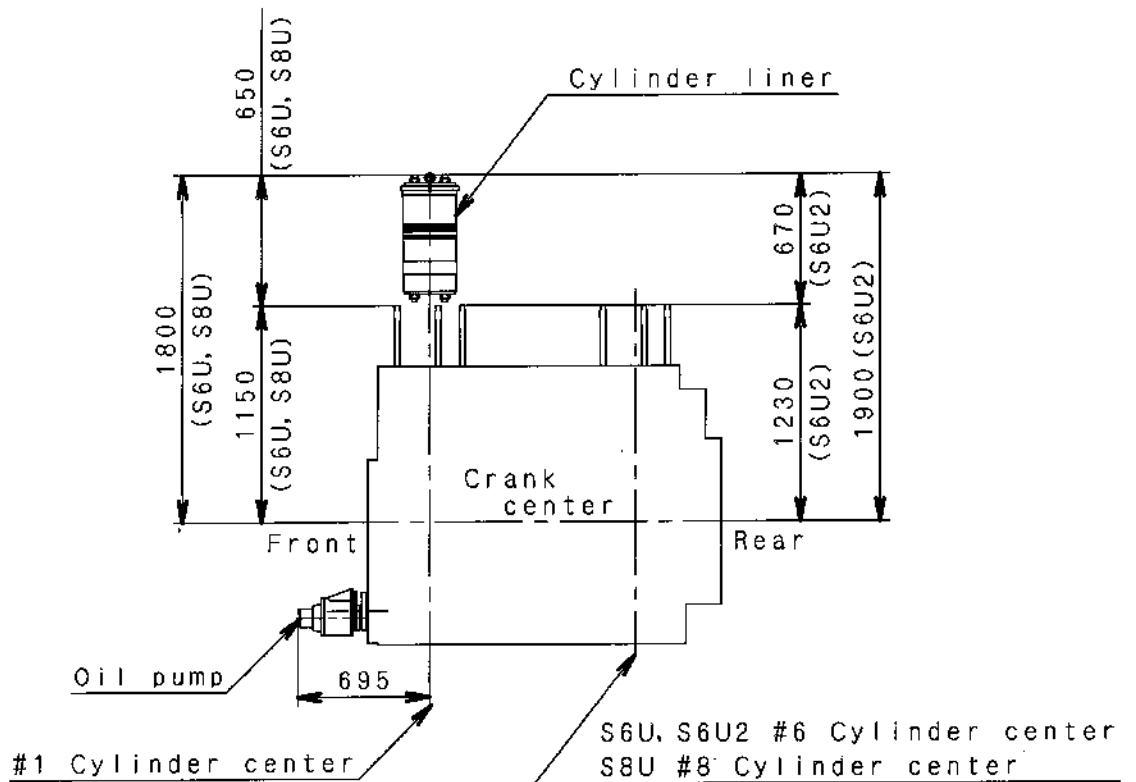
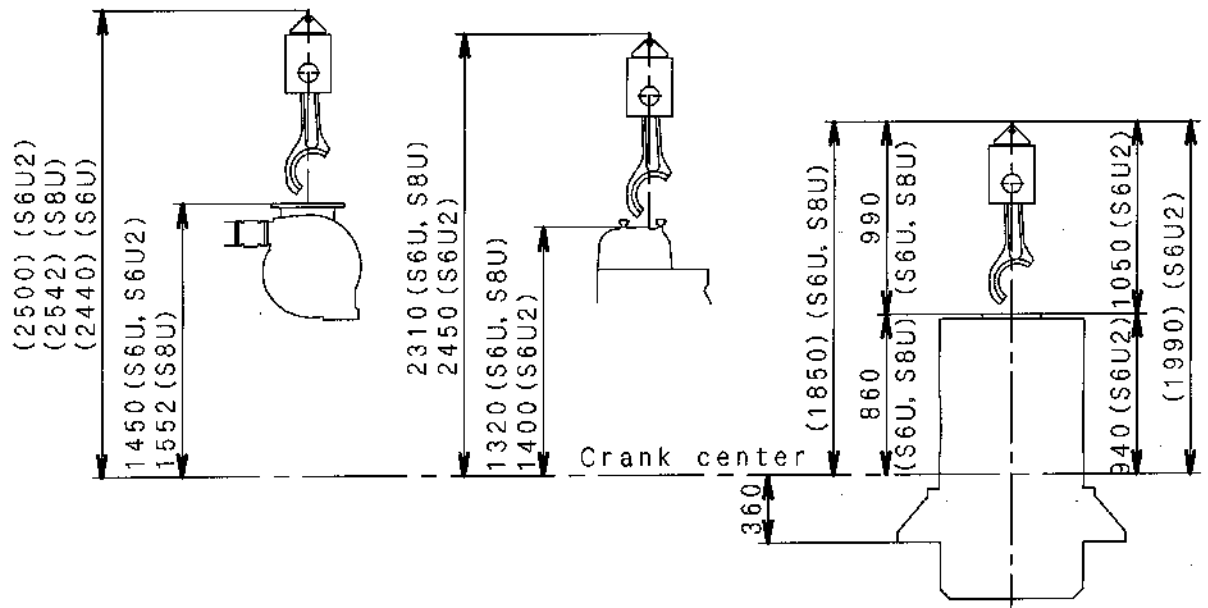

SUエンジンオーバーホール時の所要寸法
 SU ENGINE OVERHAUL HEIGHT AND LENGTH

(S6U, S6U2, S8U)

TYPE I

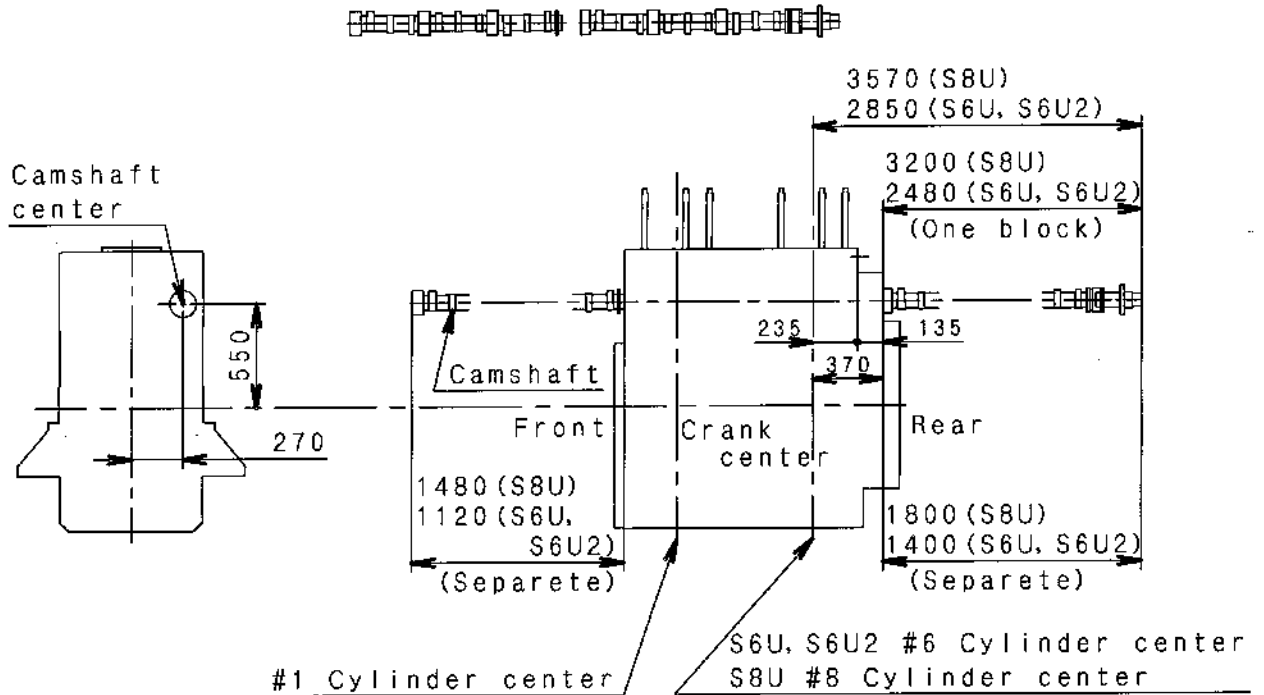

TYPE II

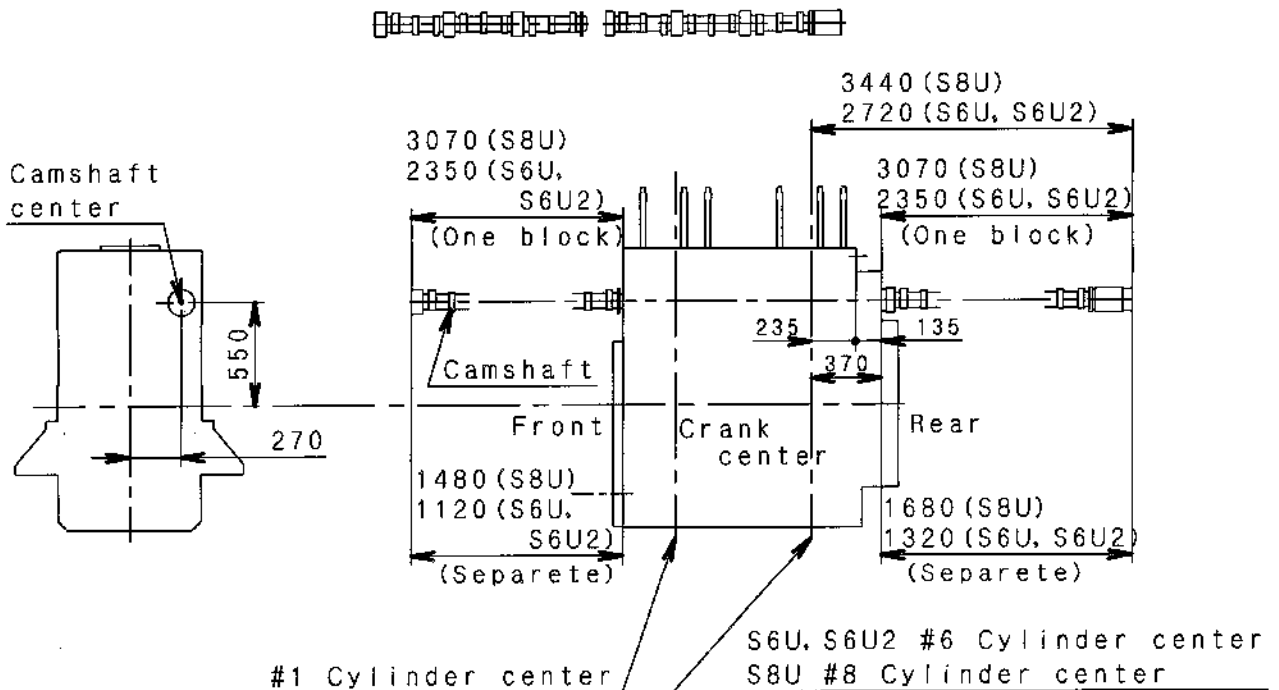

S6U2 JOINT DETAIL (1/2)

- ① FLYWHEEL
- ② FLYWHEEL HOUSING

M16 X2 TAPPED 12 HOLES EQ SP DEP. 27
1.06

M14 X2 TAPPED 16 HOLES EQ SP DEP. 24
0.94

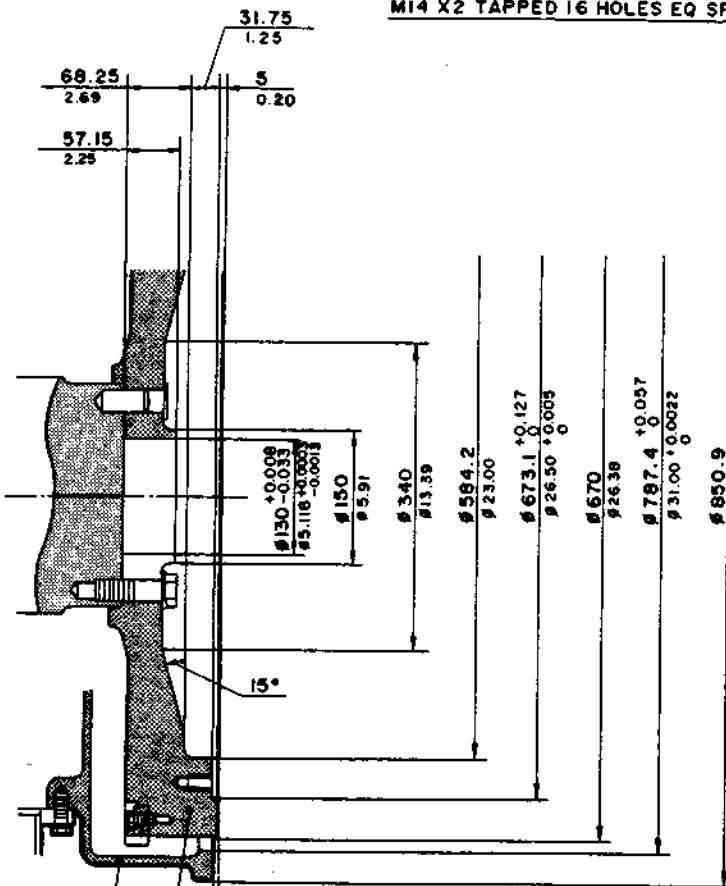

SECTION A-A

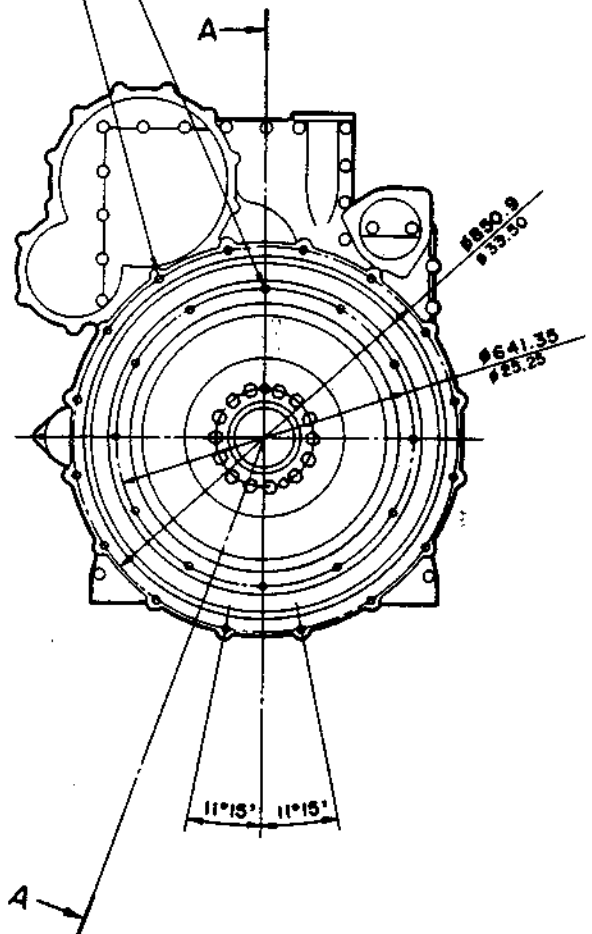

FLYWHEEL

FLYWHEEL HOUSING

JUL '87



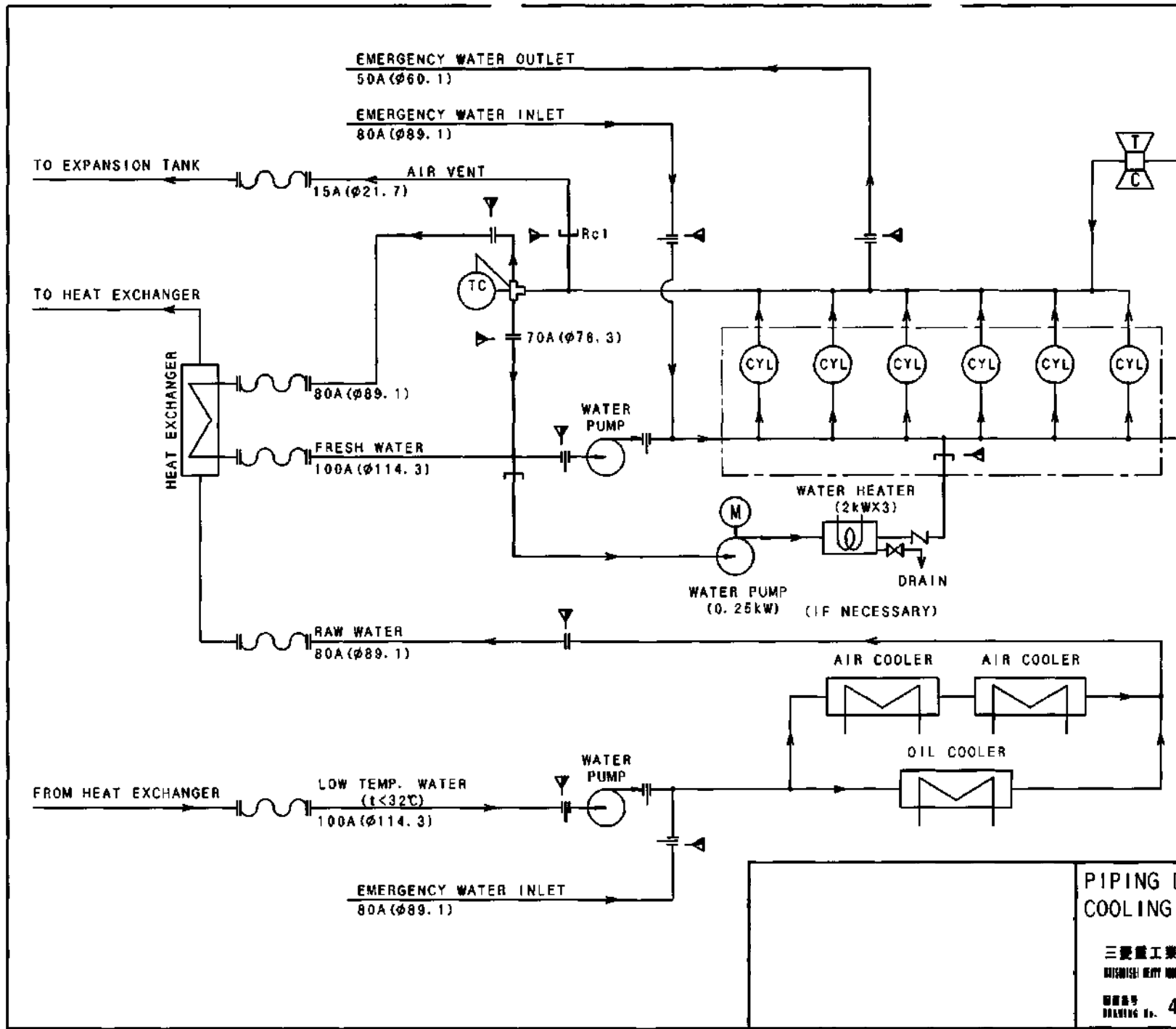

SYMBOL	DESIGNATION
	FLOW DIRECTION
	TEE PIPE CONNECTION
	FLANGED JOINT
	SPECTACLE FLANGE
	FLEXIBLE JOINT
	SCREWED JOINT
	SUPPLY SCOPE
	STOP VALVE
	CHECK VALVE
	THREE WAY THERMOSTAT
	MOTOR DRIVE
	CENTRIFUGAL TYPE PUMP
	COOLER
	HEATER
	TURBOCHARGER
	LOCALLY MOUNTED
	CYLINDER
	TEMPERATURE CONTROL

旧引

 況特
 2002
 8.0

FULL-CAD

PIPING DIAGRAM
 COOLING WATER SYSTEM MPTK

三菱重工業株式会社 汎用機・特車事業本部
 MITSUBISHI HEAVY INDUSTRIES, LTD. GENERAL MACHINERY & SPECIAL VEHICLE DEPARTMENTS

図番
 DRAWING No. 45C96-02201

2 折 図 94X' 1 特種用途品 1 供合用部品 4 確立品
 3 標準品 A 3 5 特種品 1 700 (納入品)

S6U2
 S6U
 使用光

CAPACITY OF COOLING WATER, LUBRICATING OIL AND FUEL OIL PUMP

Item	Engine speed (min ⁻¹)	Pump Capacity (l/min) / Total head (MPa)				
		S6U	S6U2	S8U	S12U	S16U
Jacket Water	1200	1300/0.17	—	1430/0.16	1700/0.17	1870/0.16
	1000	1100/0.14	1100/0.14	1210/0.13	1430/0.14	1570/0.13
	900	1000/0.12	1000/0.12	1100/0.11	1300/0.12	1430/0.11
	720 and 750	850/0.08	850/0.08	930/0.07	1100/0.08	1210/0.07
Raw water	1200	1300/0.17	—	1430/0.16	1700/0.17	1870/0.16
	1000	1100/0.14	1100/0.14	1210/0.13	1430/0.14	1570/0.13
	900	1000/0.12	1000/0.12	1100/0.11	1300/0.12	1430/0.11
	720 and 750	850/0.08	850/0.08	930/0.07	1100/0.08	1210/0.07
Lube oil	1200	550/0.56	—	725/0.56	1024/0.65	1300/0.85
	1000	460/0.52	604/0.52	604/0.52	850/0.57	1080/0.57
	900	410/0.50	544/0.50	544/0.50	770/0.53	980/0.53
	720 and 750	330/0.40	435/0.40	435/0.40	610/0.42	780/0.42
Fuel oil	1200	22.5/0.20	—	22.5/0.20	22.5/0.20	22.5/0.20
	1000	18.8/0.20	18.8/0.20	18.8/0.20	18.8/0.20	18.8/0.20
	900	16.9/0.20	16.9/0.20	16.9/0.20	16.9/0.20	16.9/0.20
	720 and 750	14.1/0.20	14.1/0.20	14.1/0.20	14.1/0.20	14.1/0.20

SU Water Pump Performance

